

PROJETO ESTRUTURAL - REFORMA DA SUPERINTENDÊNCIA DE RECURSOS MATERIAIS
ESCALA INDICADA

B1
1xC20
PLANTA
ESC 1:25

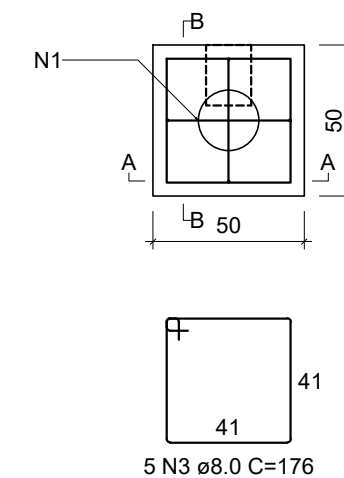

CORTE A-A
ESC 1:25

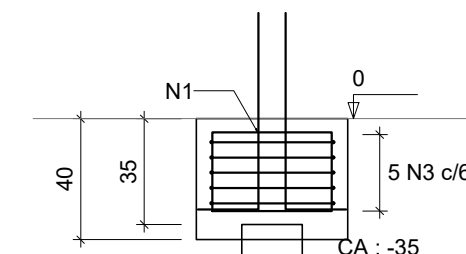

CORTE B-B
ESC 1:25

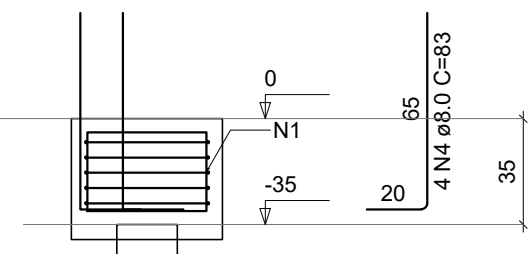

DETALHE DO PILAR
ESC 1:20

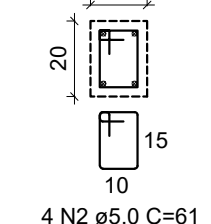

B2
1xC20
PLANTA
ESC 1:25

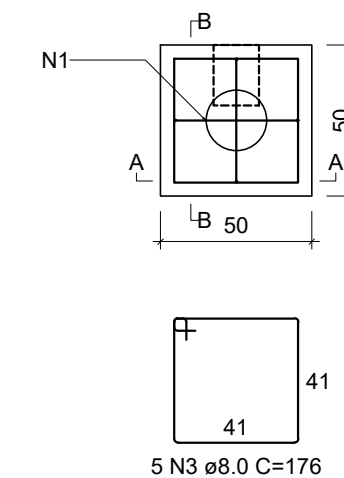

CORTE A-A
ESC 1:25

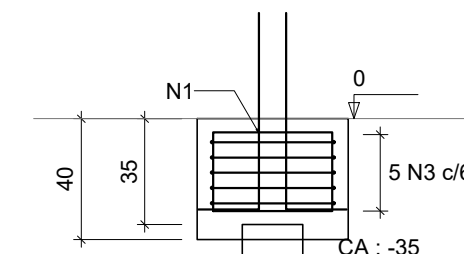

CORTE B-B
ESC 1:25

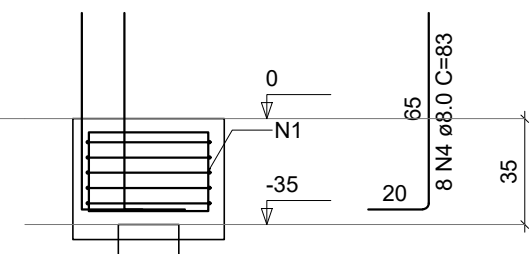

DETALHE DO PILAR
ESC 1:20

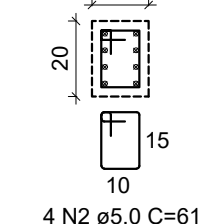

B3
1xC20
PLANTA
ESC 1:25

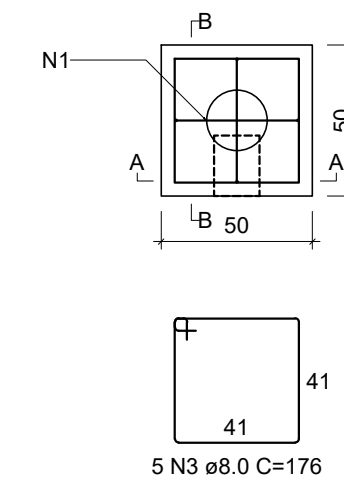

CORTE A-A
ESC 1:25

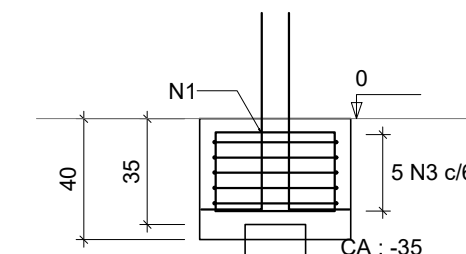

CORTE B-B
ESC 1:25

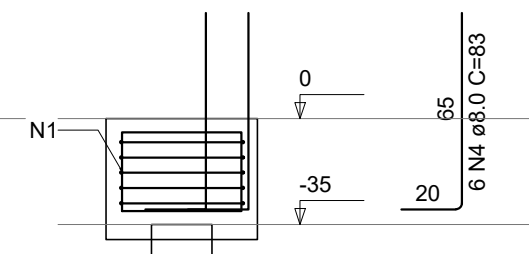

DETALHE DO PILAR
ESC 1:20

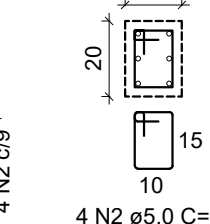

B4=B5=B8=B9=B10
1xC20
PLANTA
ESC 1:25

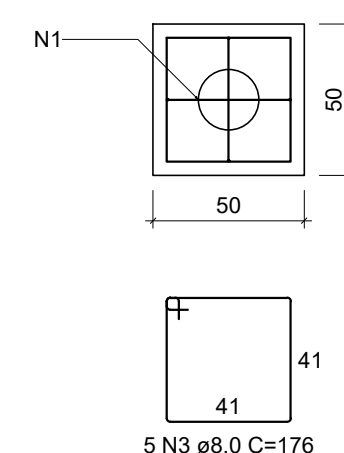

CORTE
ESC 1:25

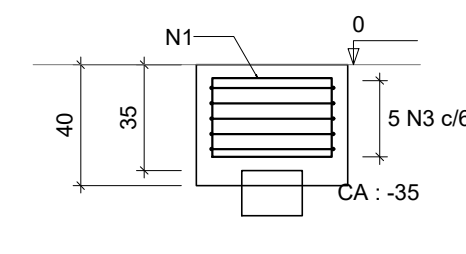

B6
1xC20
PLANTA
ESC 1:25

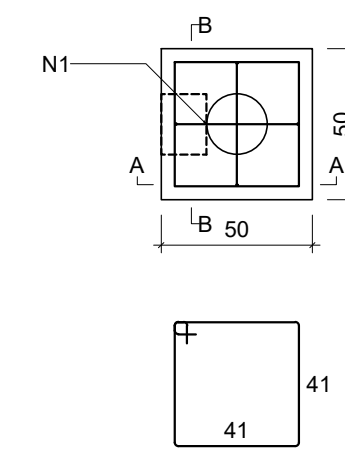

CORTE A-A
ESC 1:25

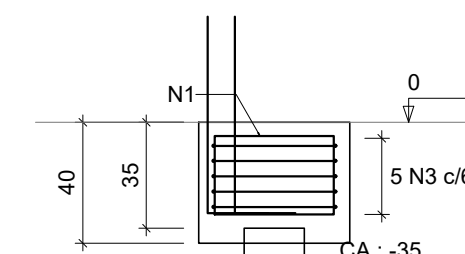

CORTE B-B
ESC 1:25

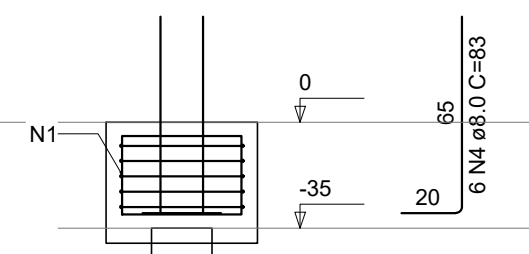

DETALHE DO PILAR
ESC 1:20

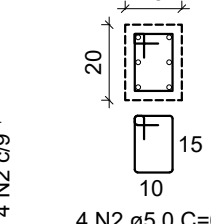

B7
1xC20
PLANTA
ESC 1:25

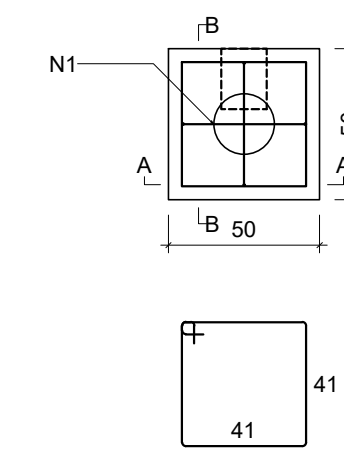

CORTE A-A
ESC 1:25

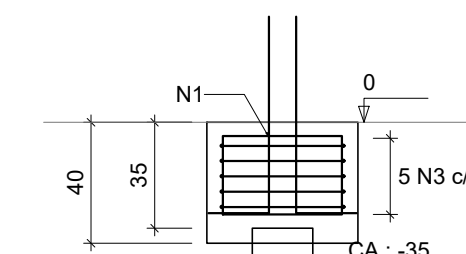

CORTE B-B
ESC 1:25

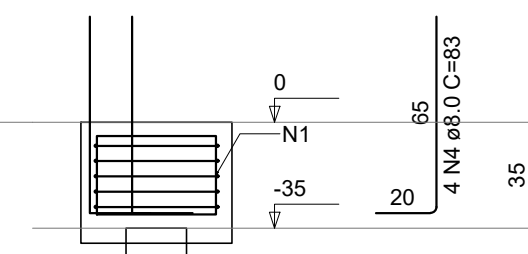

DETALHE DO PILAR
ESC 1:20

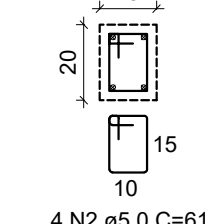

B11
1xC20
PLANTA
ESC 1:25

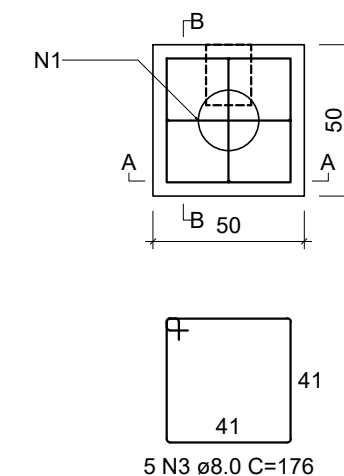

CORTE A-A
ESC 1:25

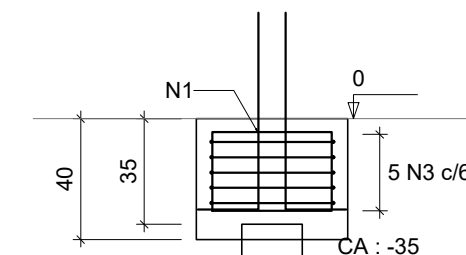

CORTE B-B
ESC 1:25

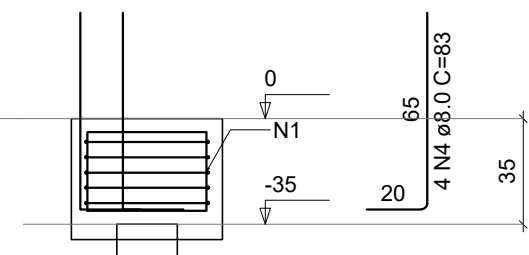

DETALHE DO PILAR
ESC 1:20

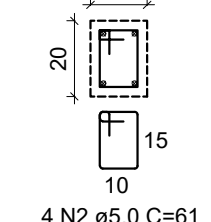

DETALHAMENTO DOS BLOCOS
Esc Indicada

RELAÇÃO DO AÇO

AÇO	N	DIAM (mm)	QUANT	C.UNIT (cm)	C.TOTAL (cm)
CA60	1	5.0	22	141	3102
CA60	2	5.0	24	61	1464
CA60	3	8.0	55	176	9680
CA60	4	8.0	32	83	2656

RESUMO DO AÇO

AÇO	DIAM (mm)	C.TOTAL (m)	PESO + 10% (kg)
CA50	8.0	123.4	53.5
CA60	5.0	45.7	7.7
PESO TOTAL (kg)			
CA50	53.5		
CA60	7.7		

Volume de concreto (C-30) = 1.08 m³
Área de forma = 8.80 m²



Prefeitura Municipal de Pouso Alegre

PROJETO	GERÊNCIA DE PROJETOS PEDRO HENRIQUE JUSTINIANO	ENG. CIVIL
	COORDENAÇÃO DE PROJETOS ALOISIO CAETANO FERREIRA	CREA: MG-97.132/D
	RESPONSÁVEL TÉCNICO ENG. CIVIL FLÁVIA C. BARBOSA	CREA: MG-187.842/D
	PROJETO ENG. CIVIL THAIS VIVIANE COIMBRA	
	DESENHO ENG. CIVIL THAIS VIVIANE COIMBRA	
EMPREENDIMENTO		
REFORMA DA SUPERINTENDÊNCIA DE RECURSOS MATERIAIS		
ENDEREÇO RUA LUCY VAS. TEIXEIRA, 230 - B. MIRANTE DO PARAÍSO POUSO ALEGRE - MINAS GERAIS		DISCIPLINA ESTRUTURAL
ASSUNTO DETALHAMENTO DOS BLOCOS		FASE DO PROJETO EXECUTIVO
		FOLHA Nº: 03/06
DATA INICIAL 20/10/2021	ESCALA INDICADA	REVISÃO R01
ARQUIVO DAC-PMPA-SRM-EST-PE-R01.DWG		

REV. 01	24/11/2021	ALTERAÇÕES CONFORME SOLICITAÇÃO DA SUPERINTENDÊNCIA	DAC
REV. 00	20/10/21	EMIÇÃO INICIAL	DAC
REVISÃO	DATA:	DESCRIÇÃO:	RESP.: