

RELAÇÃO DO AÇO

AÇO	N	DIAM (mm)	QUANT	C.UNIT (cm)	C.TOTAL (cm)
CA50	1	6.3	157	78	12246
	2	6.3	44	108	4752
	3	6.3	361	98	35378
	4	6.3	4	corr	2276
	5	6.3	97	118	11446
	6	6.3	2	78	152
	7	8.0	2	463	926
	8	8.0	4	490	1960
	9	8.0	2	456	912
	10	8.0	2	183	366
	11	8.0	2	623	1246
	12	8.0	8	366	2928
	13	8.0	4	381	1524
	14	8.0	2	571	1142
	15	8.0	2	585	1170
	16	8.0	2	619	1238
	17	10.0	1	468	936
	18	8.0	2	711	1422
	19	8.0	4	346	1384
	20	8.0	2	380	760
	21	8.0	2	173	346
	22	8.0	2	203	406
	23	8.0	2	244	488
	24	8.0	2	210	420
	25	10.0	8	459	3672
	26	10.0	1	456	456
	27	10.0	1	354	354
	28	10.0	2	588	1176
	29	10.0	2	479	958
	30	10.0	2	740	1480
	31	10.0	6	662	3972
	32	10.0	2	755	1510
	33	10.0	3	794	1588
	34	10.0	2	486	972
	35	10.0	2	660	1320
	36	10.0	1	759	759
	37	10.0	3	762	2286
	38	10.0	2	748	1496
	39	10.0	4	627	2508
	40	12.5	1	209	209
	41	12.5	2	514	1028
	42	12.5	2	236	472
	43	12.5	2	514	1028
	44	12.5	1	325	325
	45	12.5	2	717	1434
	46	12.5	1	274	274
	47	12.5	2	718	1436
	48	12.5	2	659	1318
	49	12.5	1	733	733
	50	12.5	2	740	1480
	51	12.5	1	737	737
	52	12.5	2	744	1488
	53	12.5	1	338	338
	54	12.5	1	342	342
	55	12.5	1	817	817
	56	12.5	2	824	1648
	57	12.5	2	668	1336
	58	12.5	2	667	1334
	59	12.5	2	581	1162
	60	12.5	1	269	269
	61	12.5	2	620	1240
	62	12.5	2	223	446
	63	12.5	2	269	538

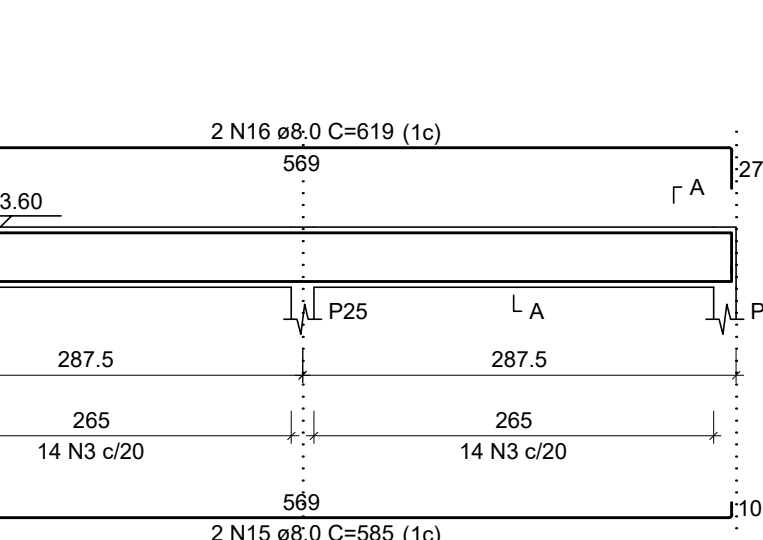
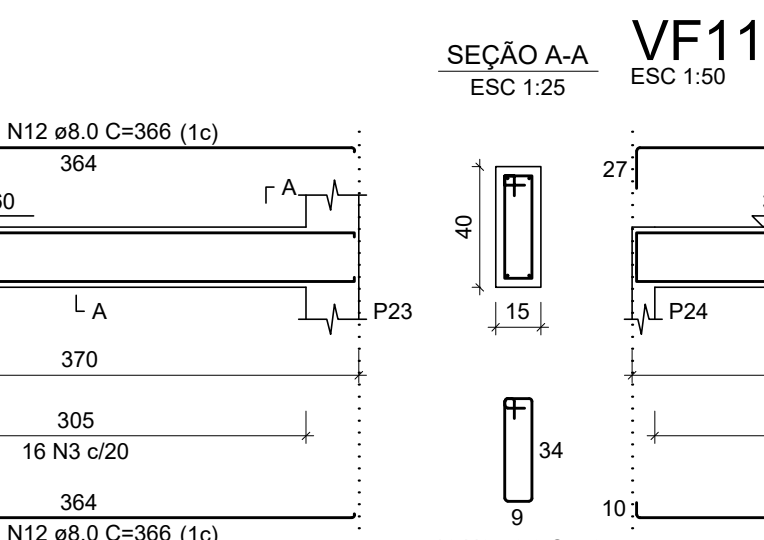
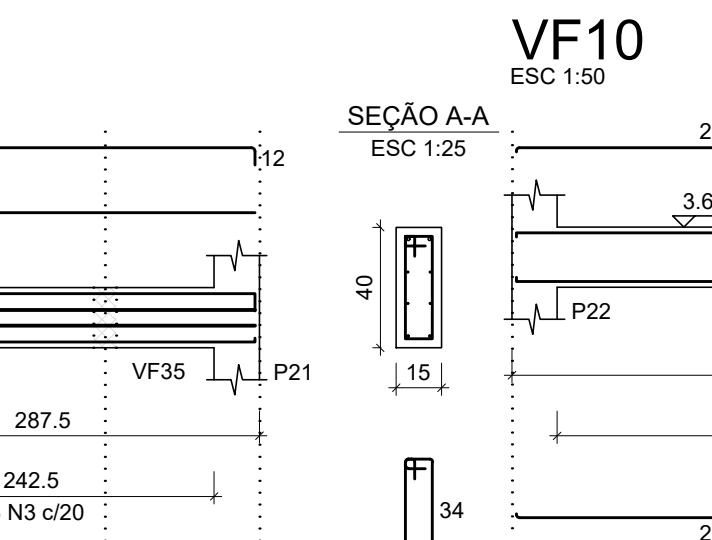
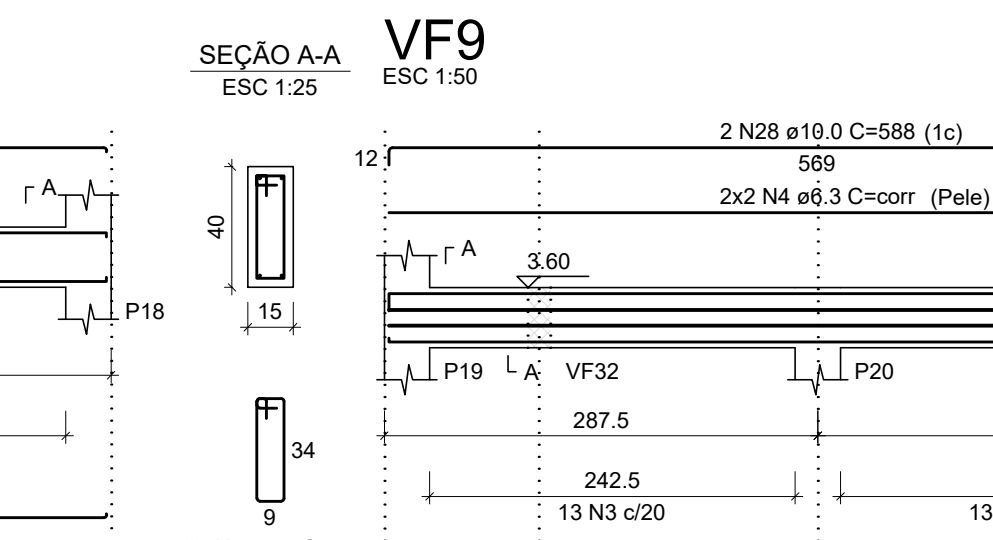
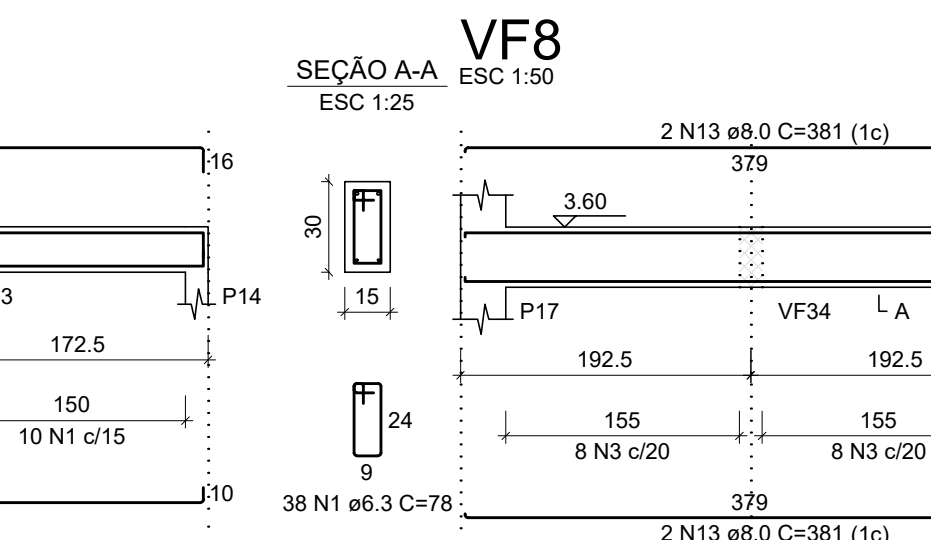
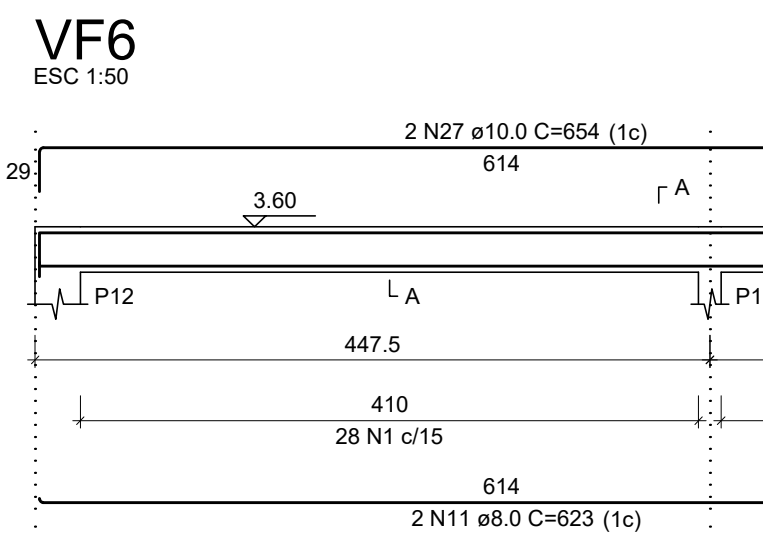

RESUMO DO AÇO

AÇO	DIAM (mm)	C.TOTAL (m)	QUANT + 10% (Barras)	PESO + 10% (kg)
CA50	6.3	662.5	61	178.3
	8.0	203.7	19	88.4
	10.0	249.8	23	169.4
	12.5	214.3	20	227.1
<b>PESO TOTAL (kg)</b>				<b>663.3</b>

Volume de concreto (C-25) = 8.47 m³  
Área de forma = 131.69 m²

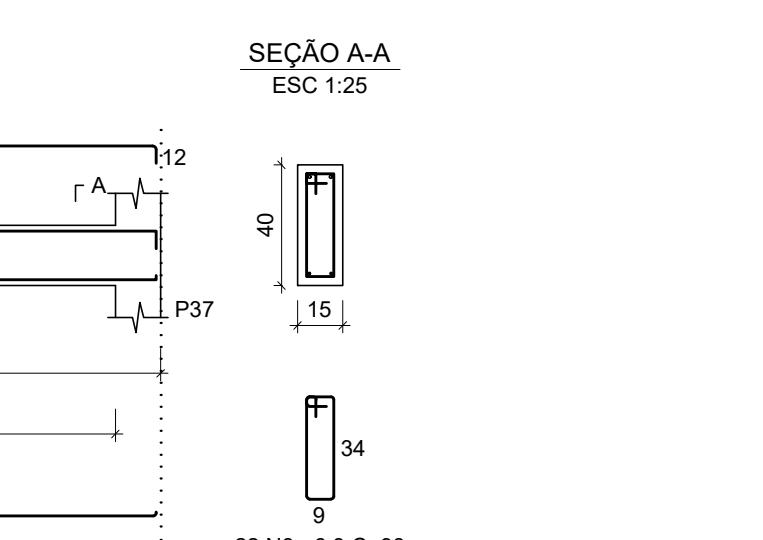
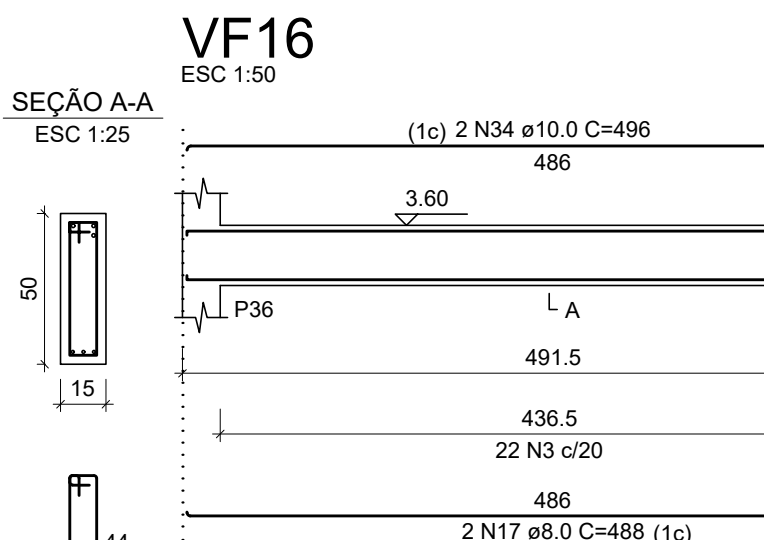
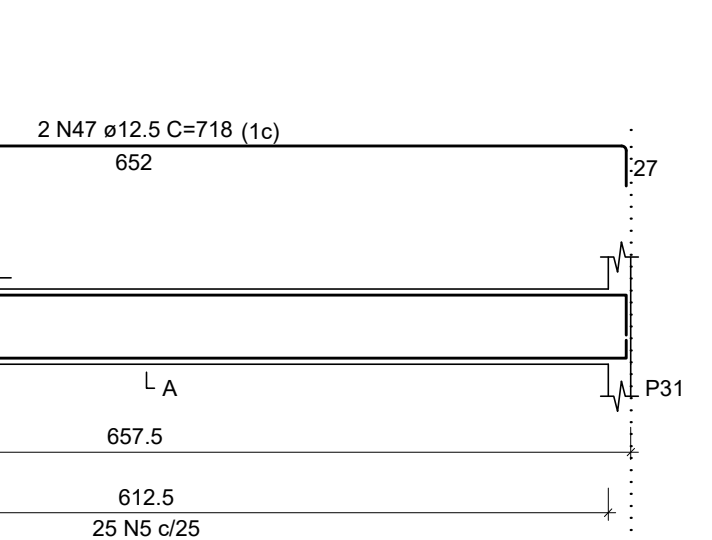
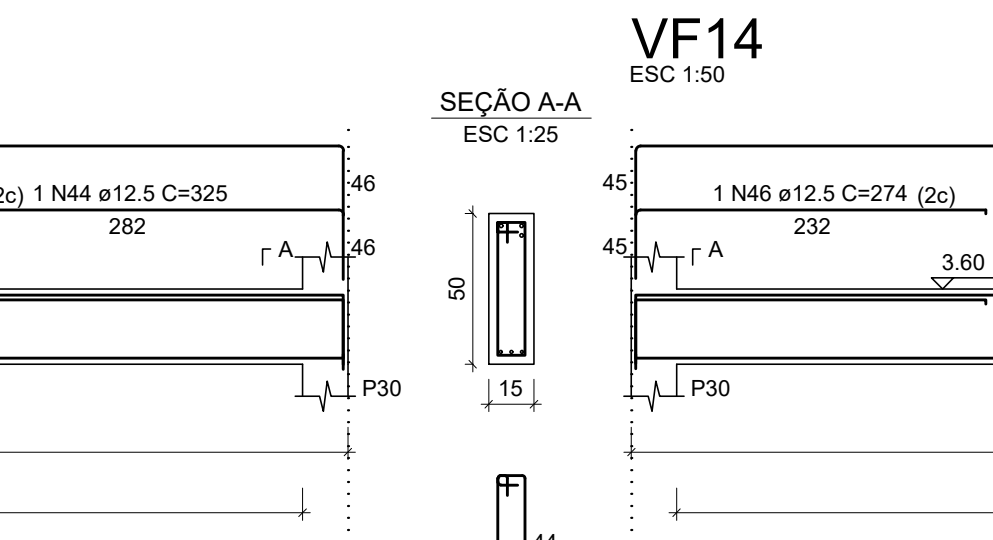
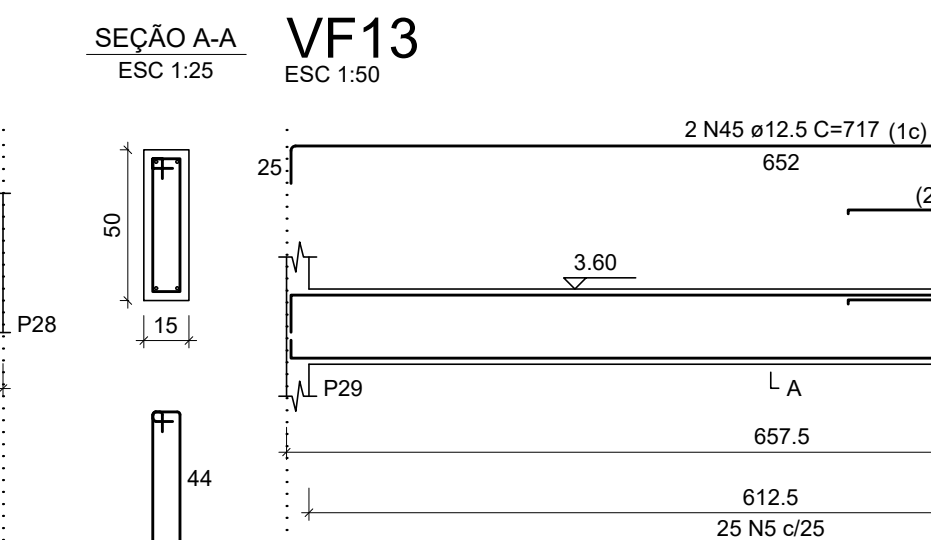
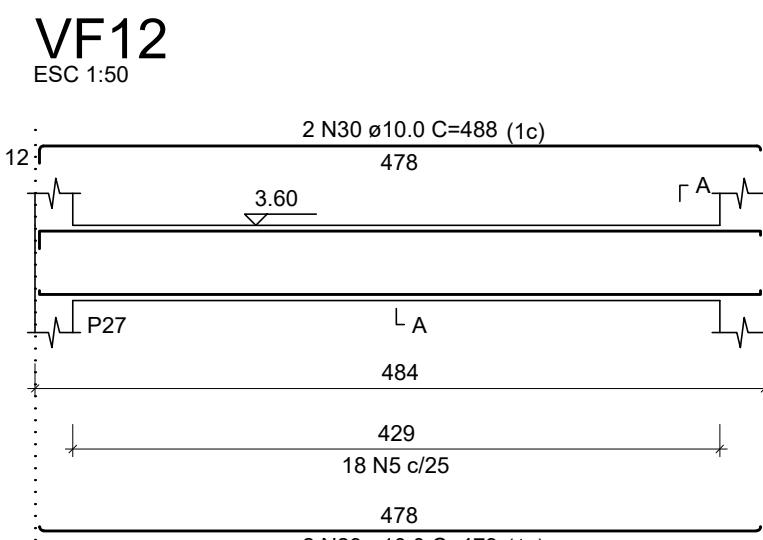

RESUMO DO AÇO

AÇO	DIAM (mm)	C.TOTAL (m)	QUANT + 10% (Barras)	PESO + 10% (kg)
CA50	6.3	662.5	61	178.3
	8.0	203.7	19	88.4
	10.0	249.8	23	169.4
	12.5	214.3	20	227.1
<b>PESO TOTAL (kg)</b>				<b>663.3</b>

Volume de concreto (C-25) = 8.47 m³  
Área de forma = 131.69 m²

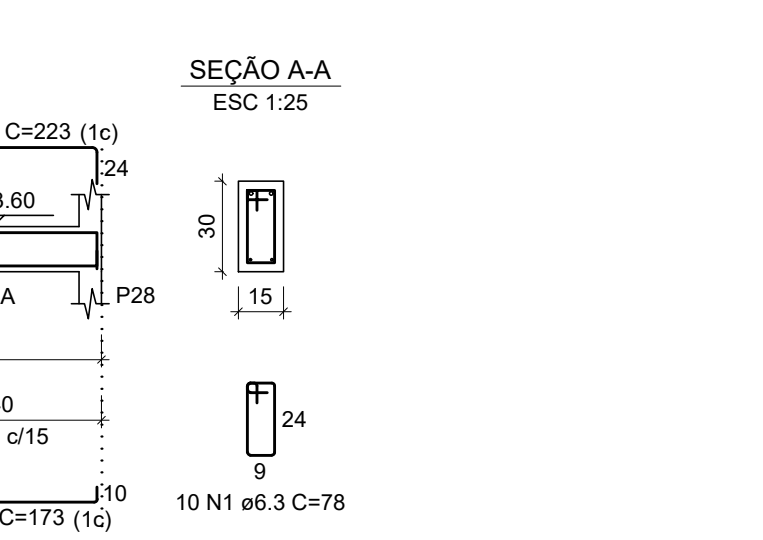
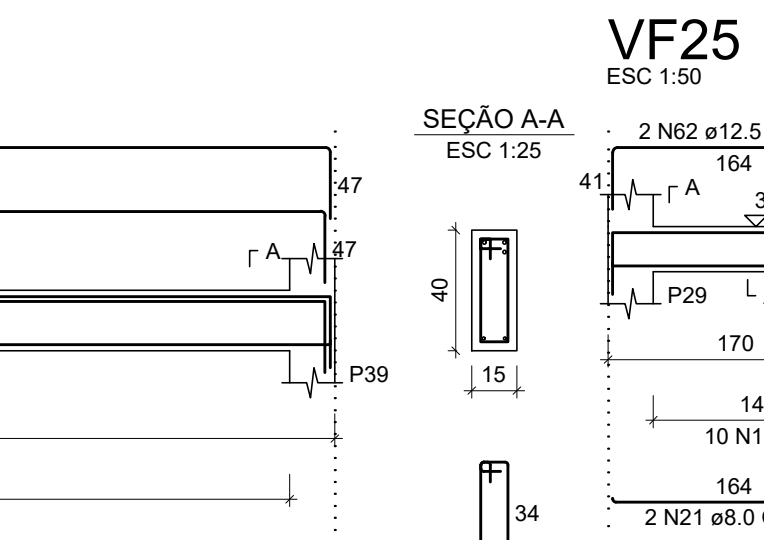
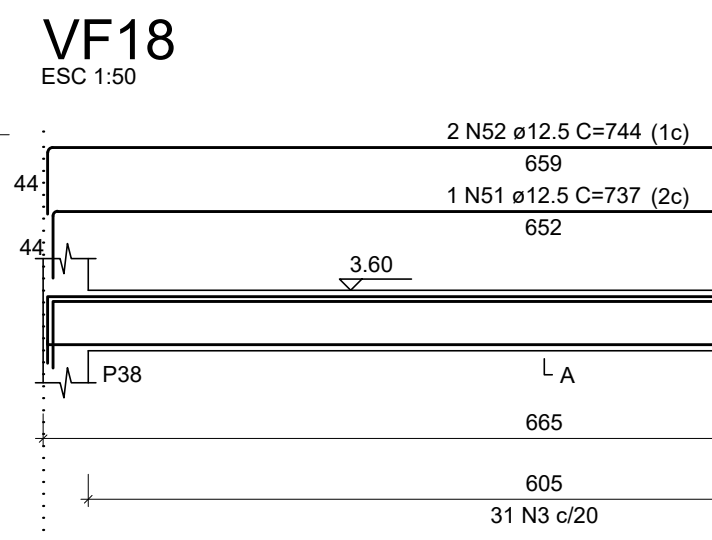
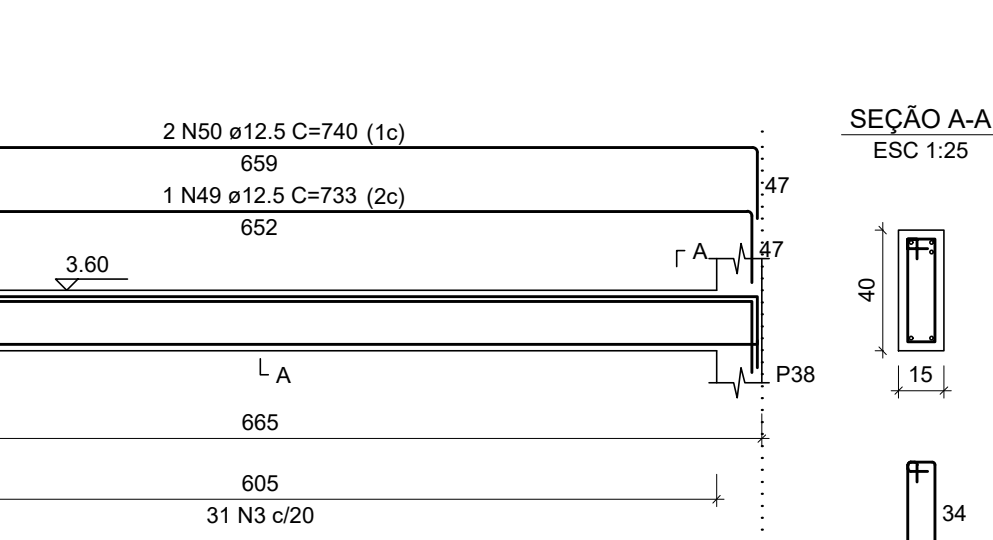
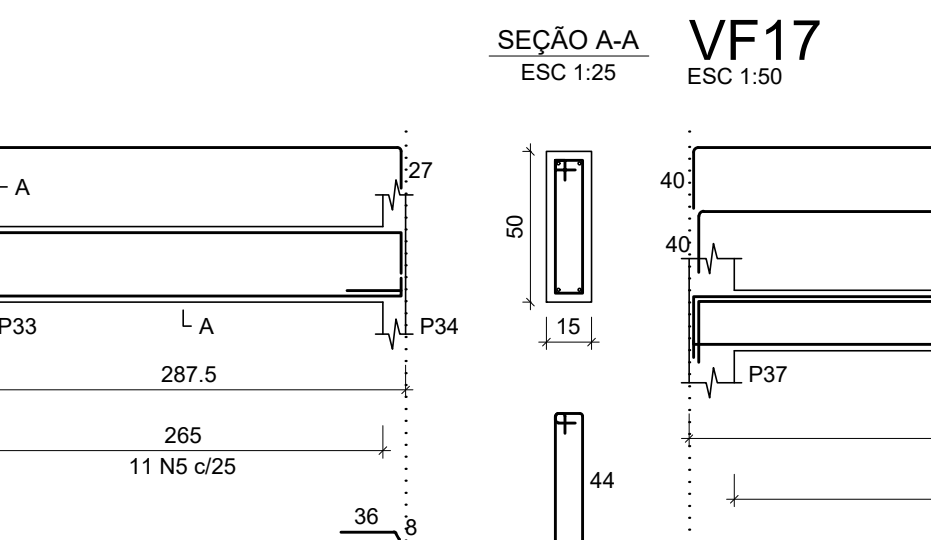
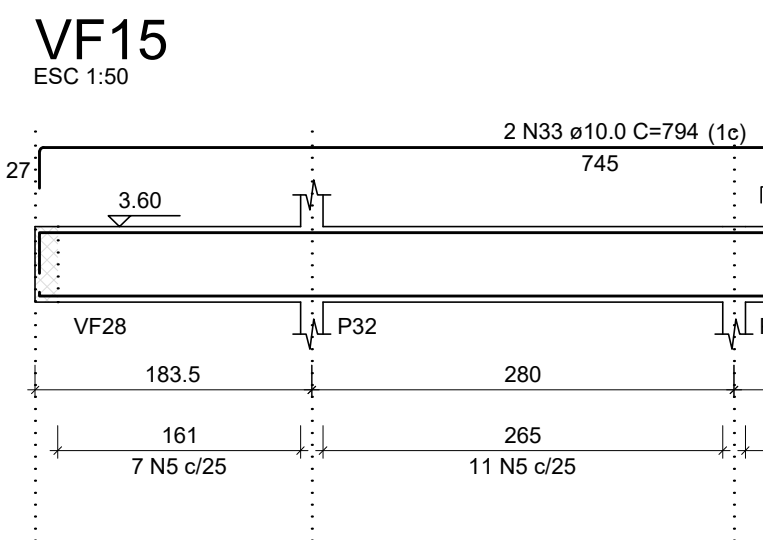

RESUMO DO AÇO

AÇO	DIAM (mm)	C.TOTAL (m)	QUANT + 10% (Barras)	PESO + 10% (kg)
CA50	6.3	662.5	61	178.3
	8.0	203.7	19	88.4
	10.0	249.8	23	169.4
	12.5	214.3	20	227.1
<b>PESO TOTAL (kg)</b>				<b>663.3</b>

Volume de concreto (C-25) = 8.47 m³  
Área de forma = 131.69 m²

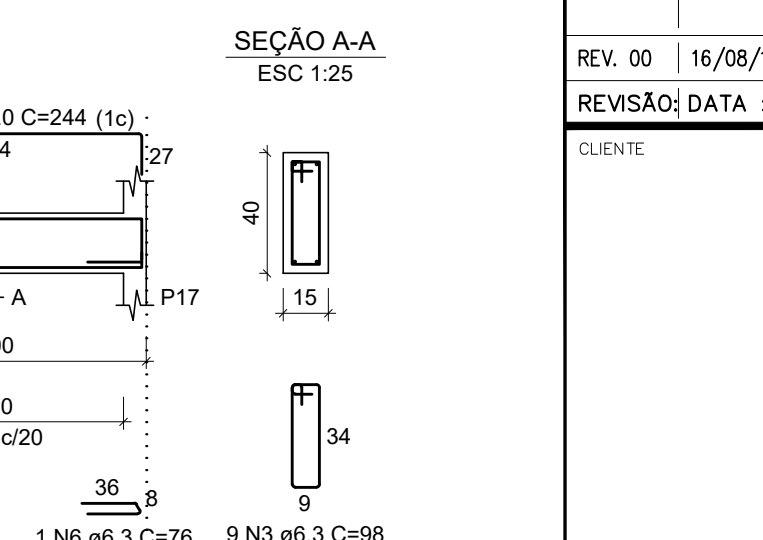
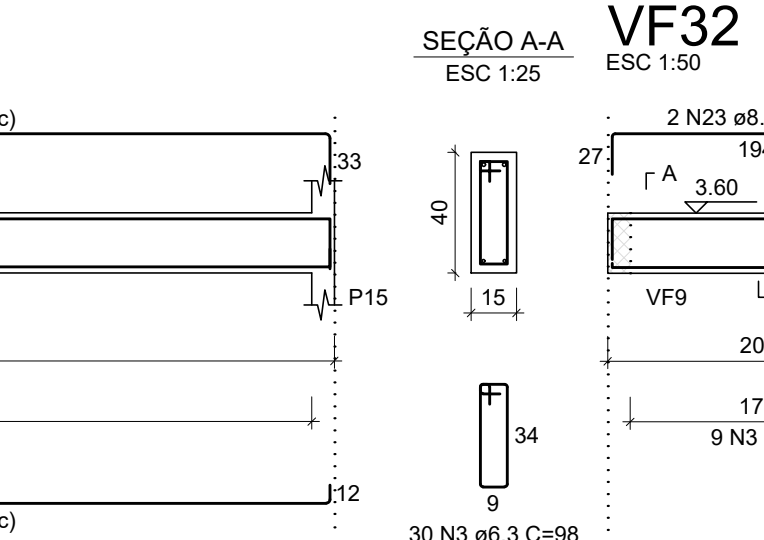
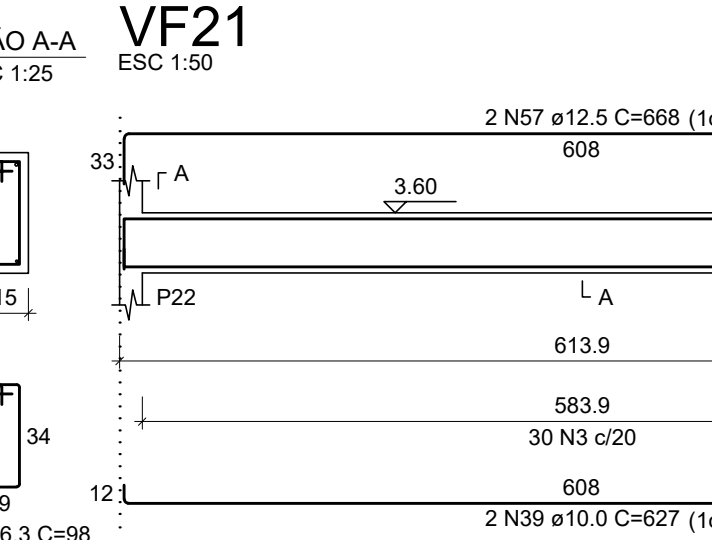
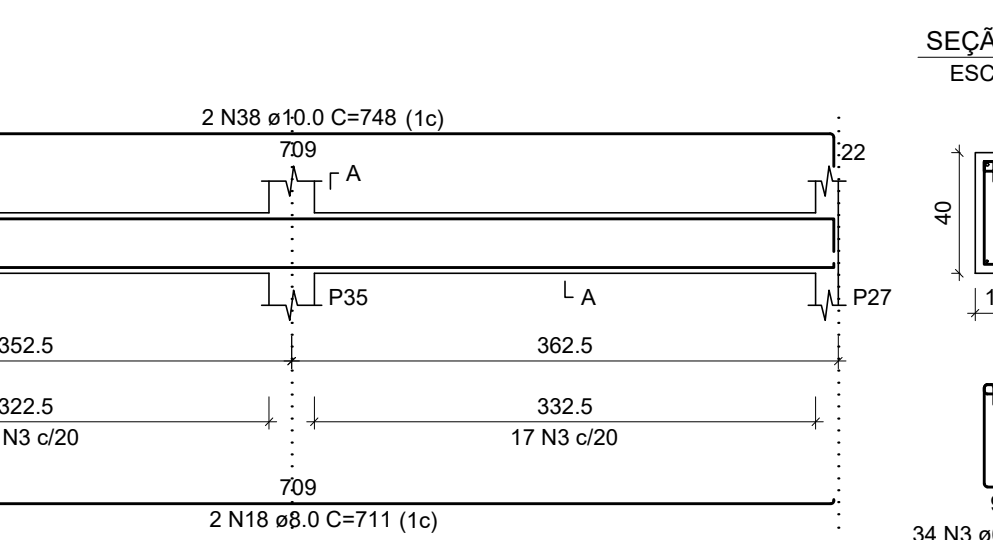
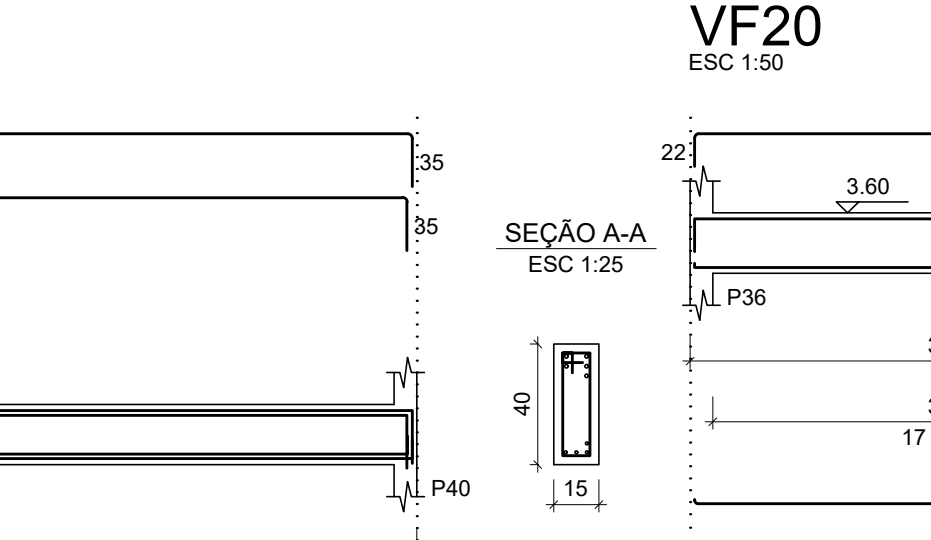
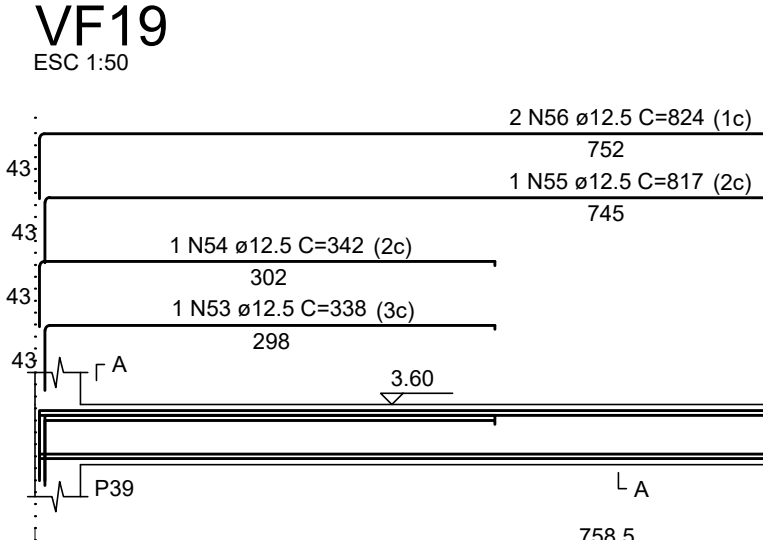

RESUMO DO AÇO

AÇO	DIAM (mm)	C.TOTAL (m)	QUANT + 10% (Barras)	PESO + 10% (kg)
CA50	6.3	662.5	61	178.3
	8.0	203.7	19	88.4
	10.0	249.8	23	169.4
	12.5	214.3	20	227.1
<b>PESO TOTAL (kg)</b>				<b>663.3</b>

Volume de concreto (C-25) = 8.47 m³  
Área de forma = 131.69 m²

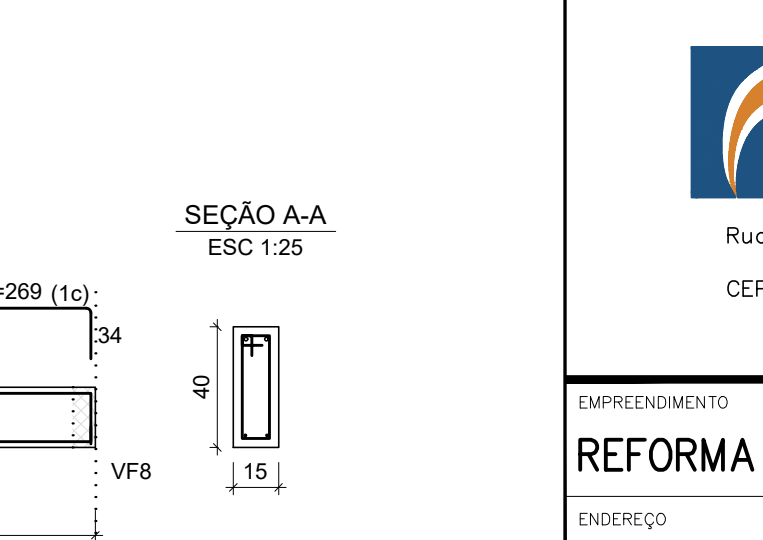
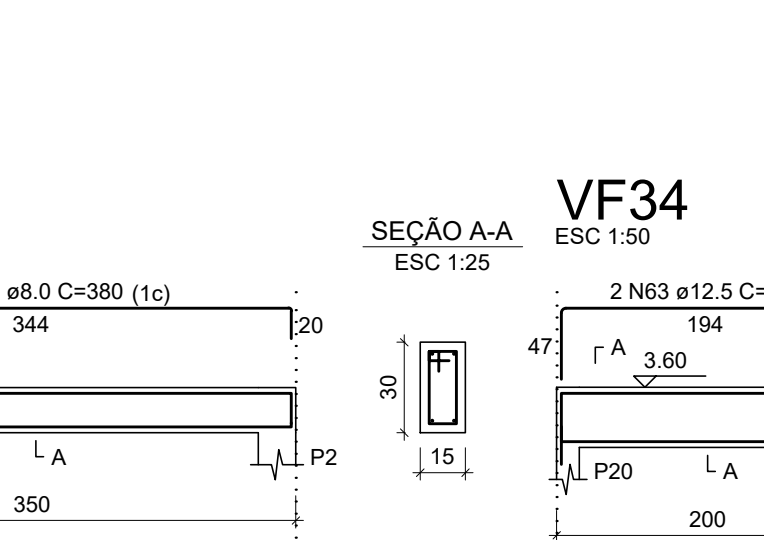
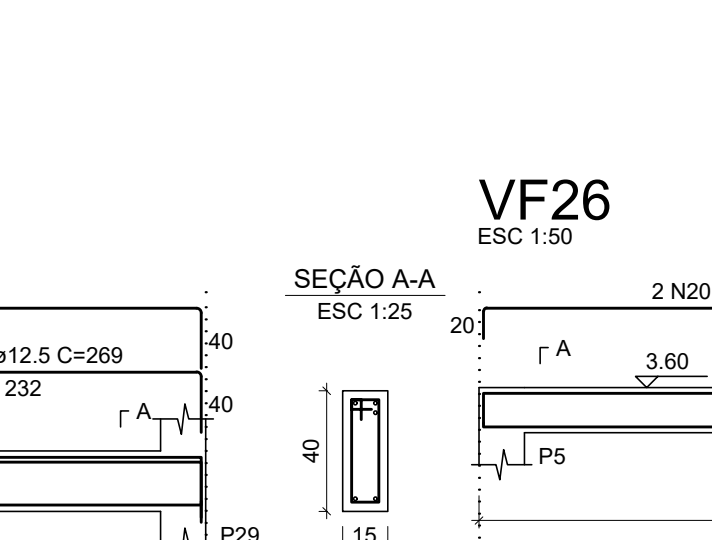
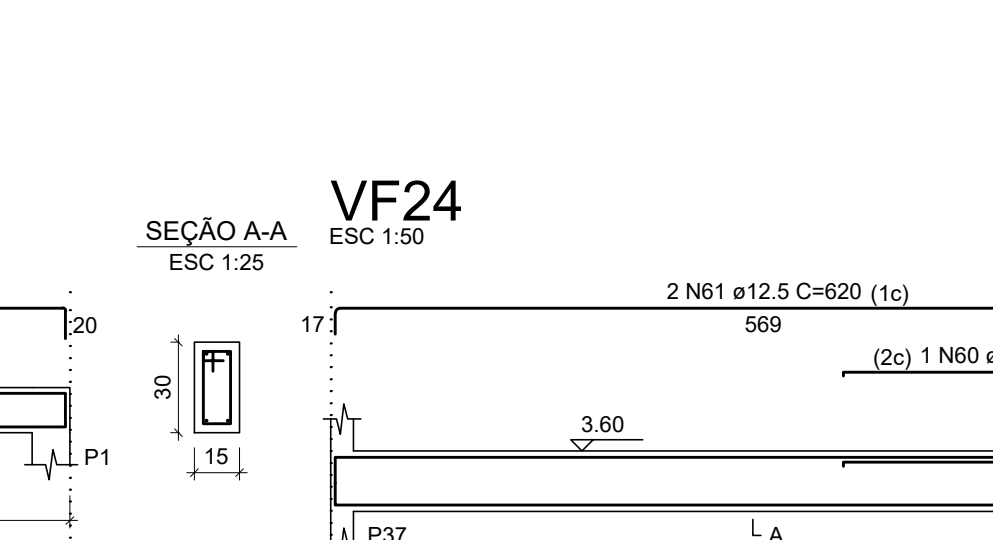
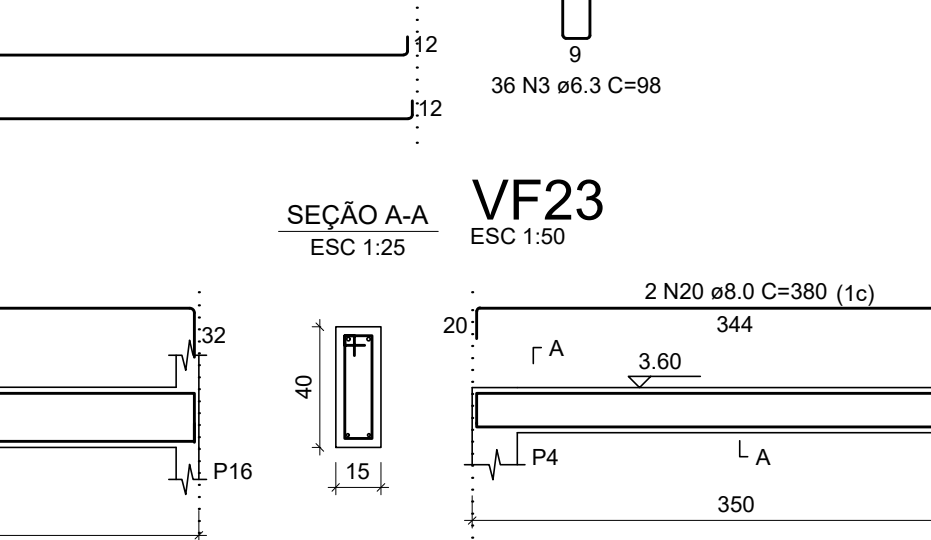
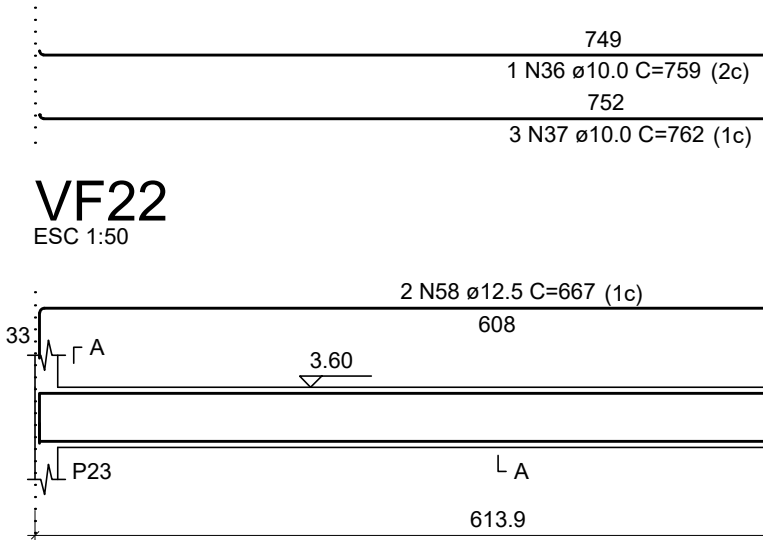

RESUMO DO AÇO

AÇO	DIAM (mm)	C.TOTAL (m)	QUANT + 10% (Barras)	PESO + 10% (kg)
CA50	6.3	662.5	61	178.3
	8.0	203.7	19	88.4
	10.0	249.8	23	169.4
	12.5	214.3	20	227.1
<b>PESO TOTAL (kg)</b>				<b>663.3</b>

Volume de concreto (C-25) = 8.47 m³  
Área de forma = 131.69 m²

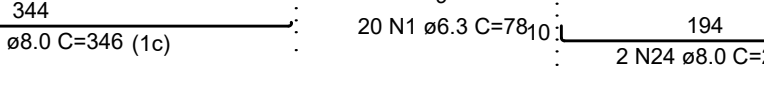
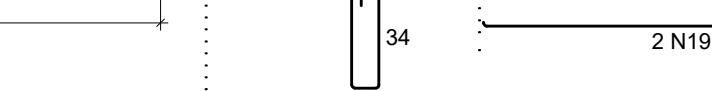
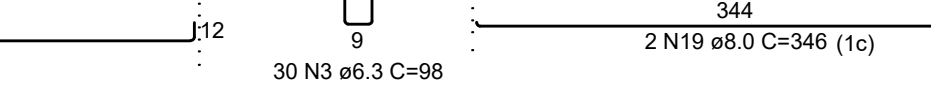
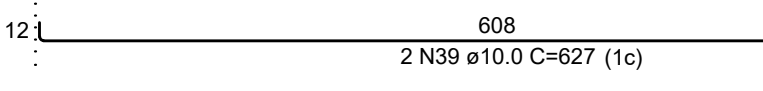

RESUMO DO AÇO

AÇO	DIAM (mm)	C.TOTAL (m)	QUANT + 10% (Barras)	PESO + 10% (kg)
CA50	6.3	662.5	61	178.3
	8.0	203.7	19	88.4
	10.0	249.8	23	169.4
	12.5	214.3	20	227.1
<b>PESO TOTAL (kg)</b>				<b>663.3</b>

Volume de concreto (C-25) = 8.47 m³  
Área de forma = 131.69 m²

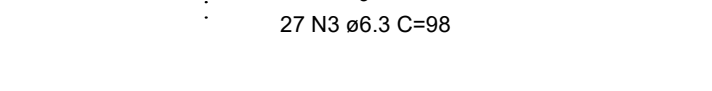

RESUMO DO AÇO

AÇO	DIAM (mm)	C.TOTAL (m)	QUANT + 10% (Barras)	PESO + 10% (kg)
CA50	6.3			