

B29=B30
2x30
PLANTA
ESC 1:20

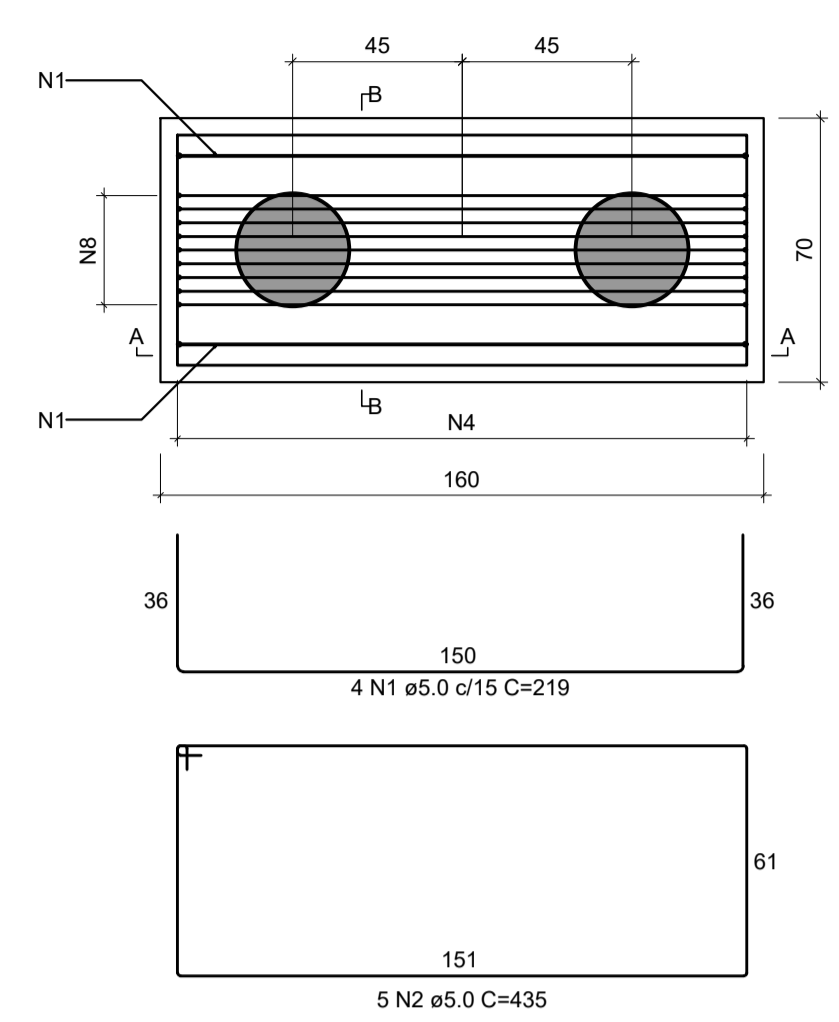

CORTE A-A
ESC 1:20

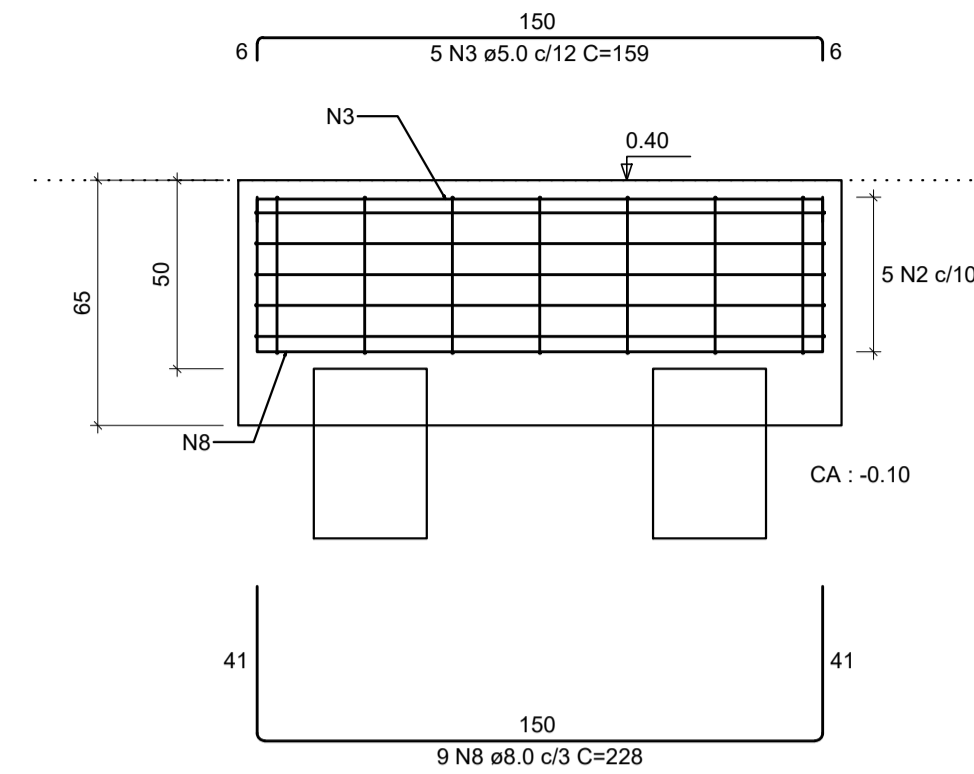

CORTE B-B
ESC 1:20

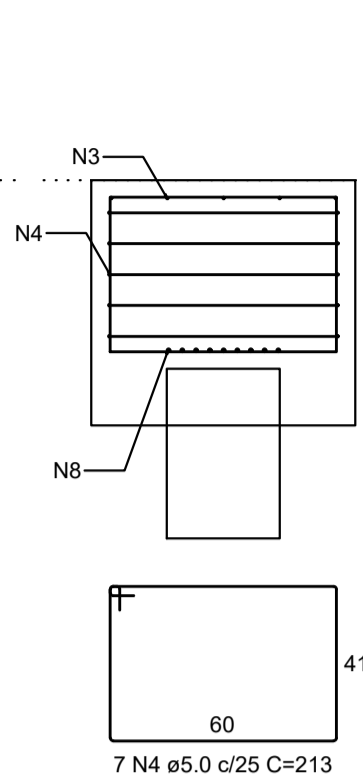

B39
2x30
PLANTA
ESC 1:20

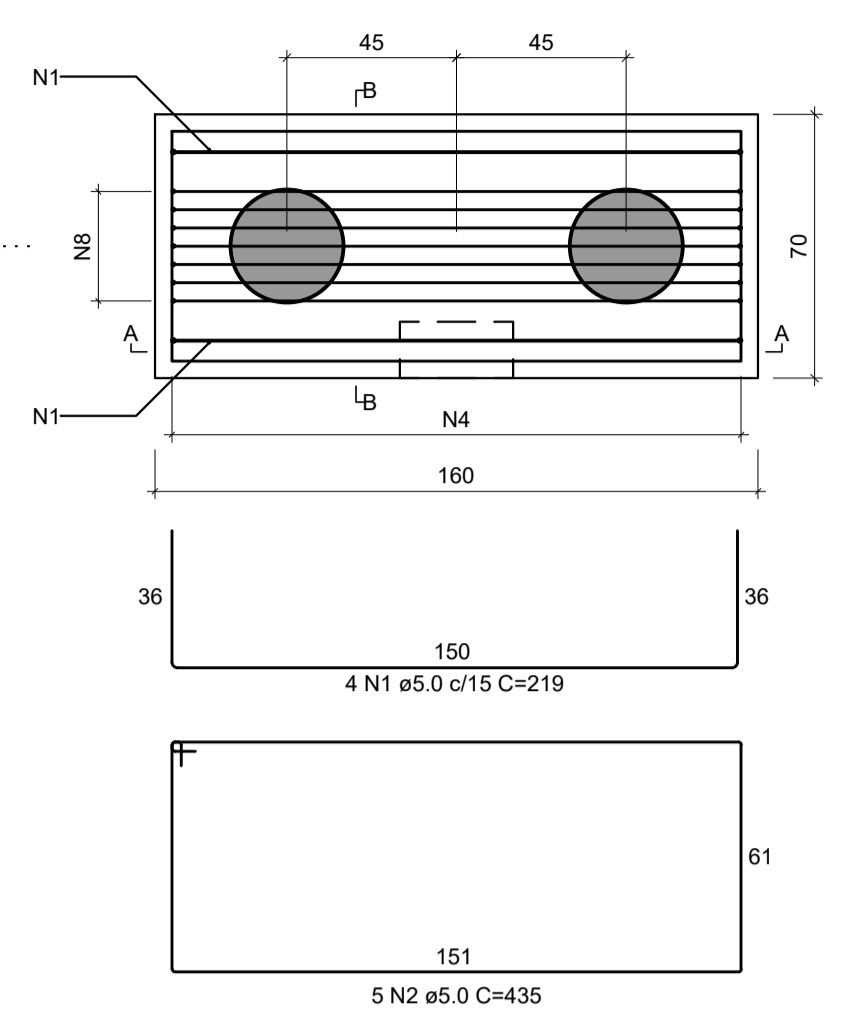

CORTE A-A
ESC 1:20

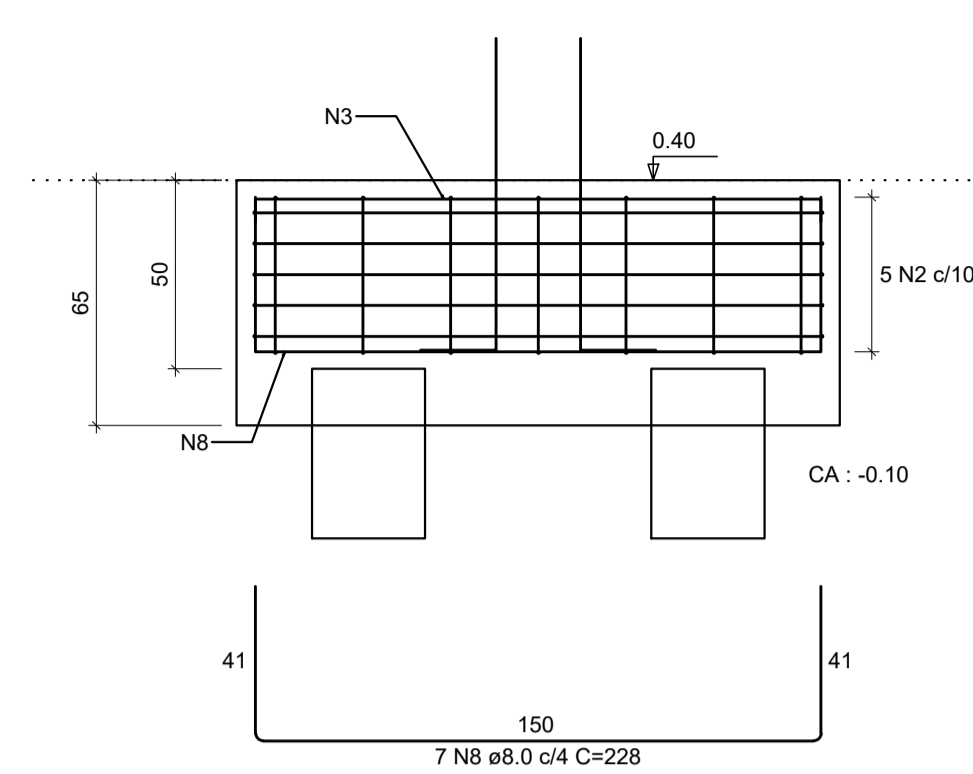

CORTE B-B
ESC 1:20

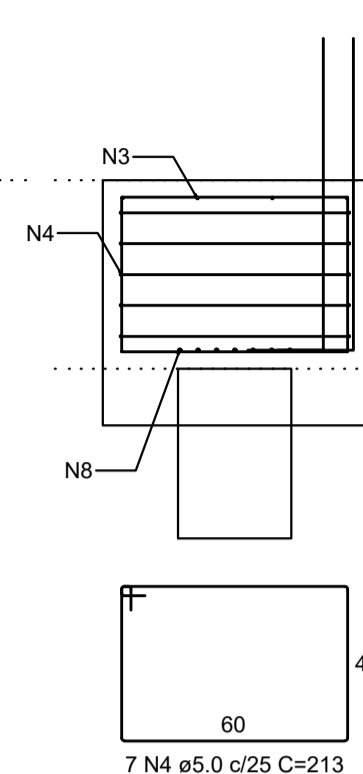

DETALHE DO PILAR
ESC 1:25

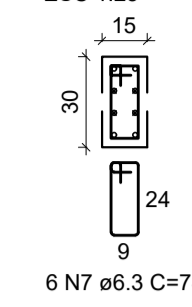

RELAÇÃO DO AÇO

AÇO	N	DIAM (mm)	QUANT	C.UNIT (cm)	C.TOTAL (cm)
CA60	1	5.0	20	219	4380
	2	5.0	25	435	10875
	3	5.0	22	159	3498
	4	5.0	35	213	7455
	5	5.0	78	255	19890
CA50	6	5.0	26	263	6838
	7	6.3	17	78	1326
	8	8.0	31	228	7068
	9	10.0	4	227	908
	10	10.0	14	101	1414
	11	12.5	8	109	872

RESUMO DO AÇO

AÇO	DIAM (mm)	C. TOTAL (m)	QUANT + 10% (Barras)	PESO + 10% (kg)
CA50	6.3	13.3	2	3.6
	8.0	70.7	7	30.7
	10.0	23.2	3	15.7
	12.5	8.7	1	9.2
CA60	5.0	529.4	-	89.8
PESO TOTAL (kg)				
CA50				59.2
CA60				89.8

Volume de concreto (C-25) = 7.54 m³
Área de forma = 38.61 m²

B38
2x30
PLANTA
ESC 1:20

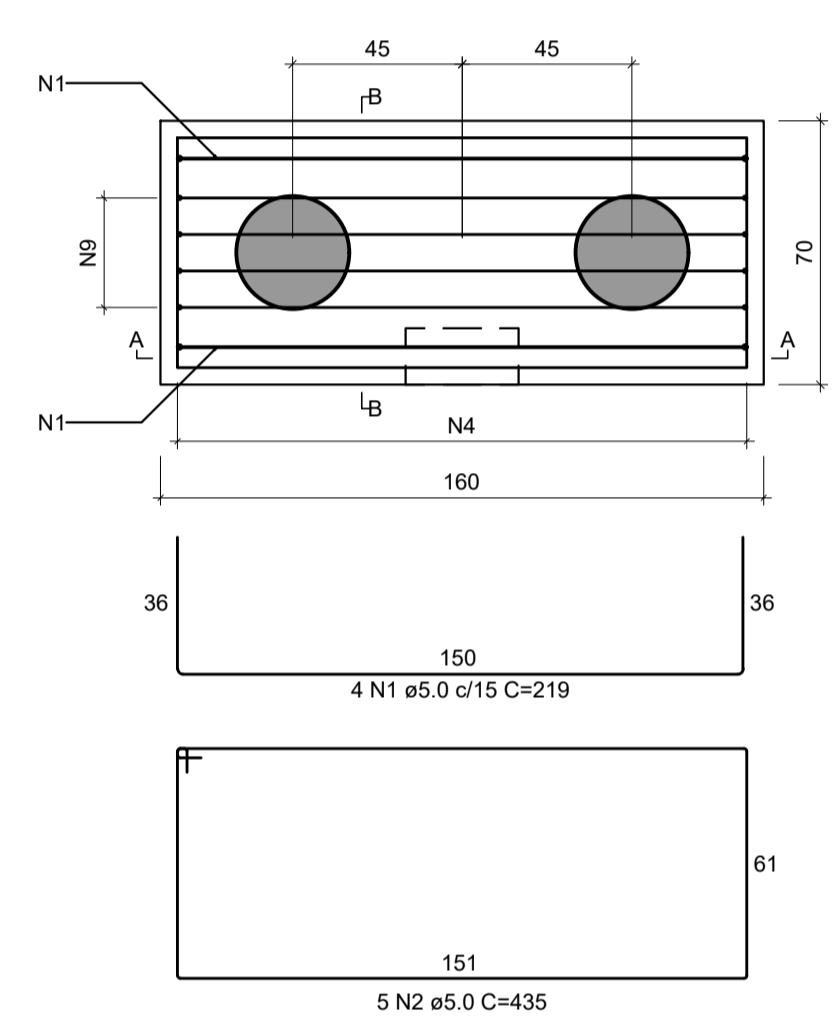

CORTE A-A
ESC 1:20

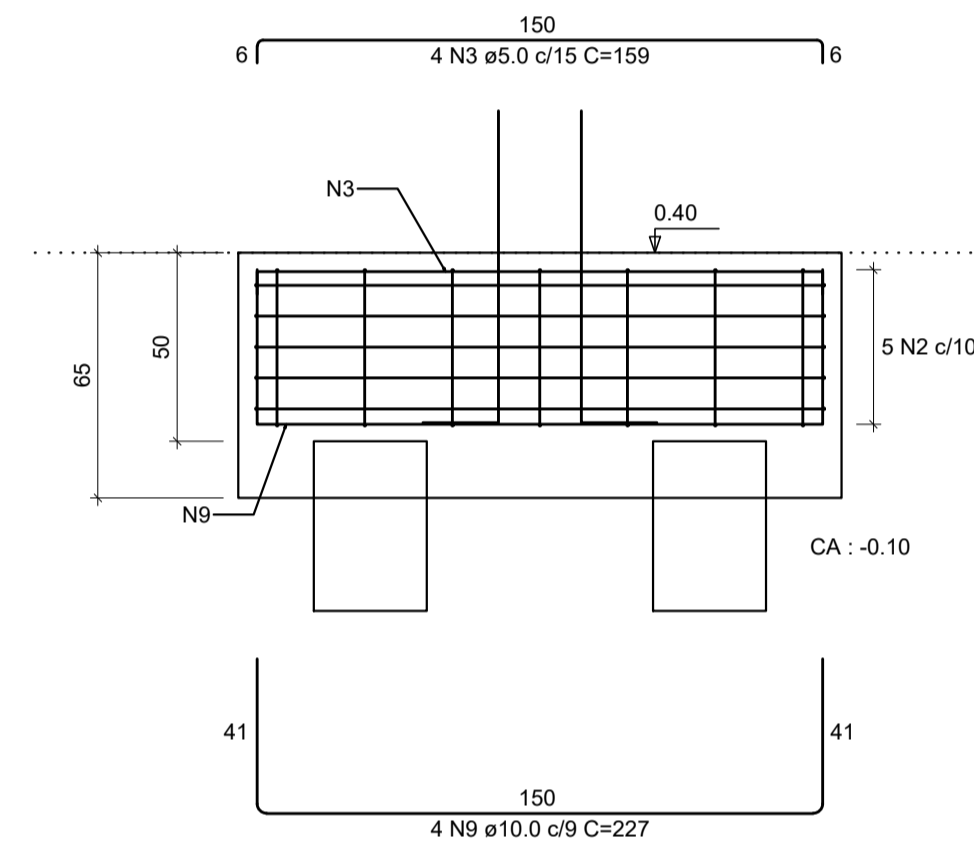

CORTE B-B
ESC 1:20

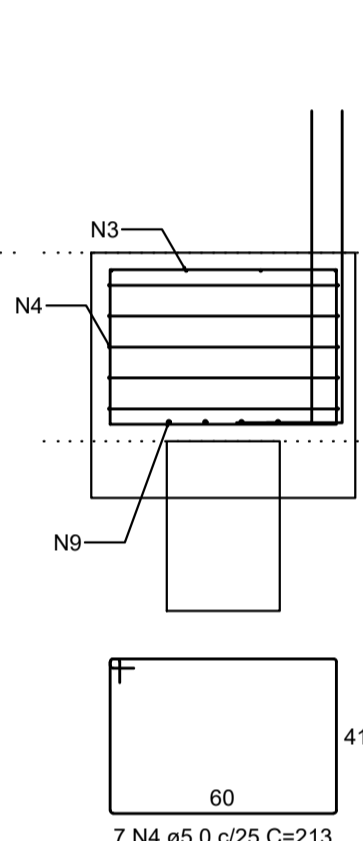

DETALHE DO PILAR
ESC 1:25

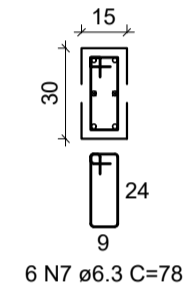

B1=B2=B3=B4=B5=B15=B16=B22=B23=B27=B28
=B31=B35
1x30
PLANTA
ESC 1:20

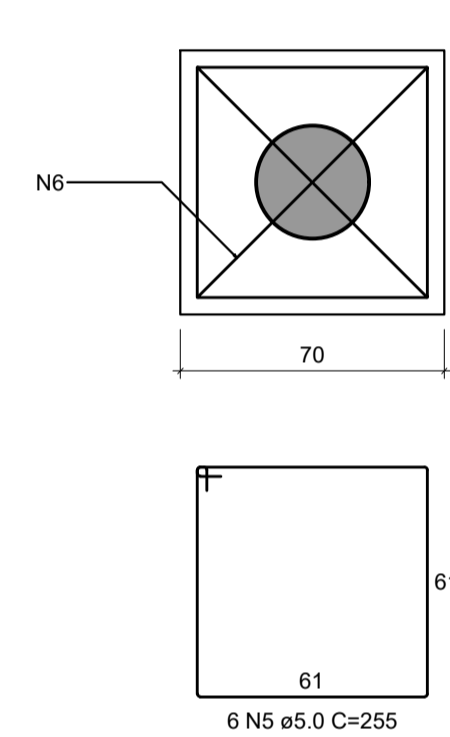

CORTE
ESC 1:20

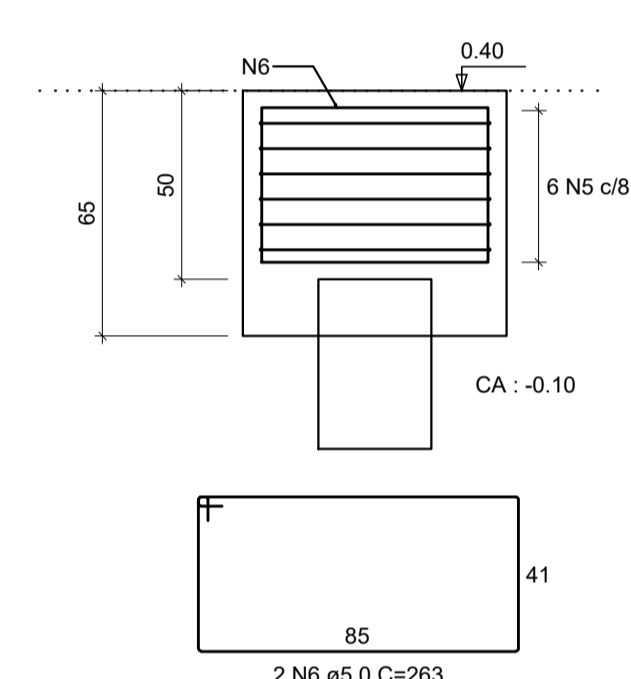

B37
2x30
PLANTA
ESC 1:20

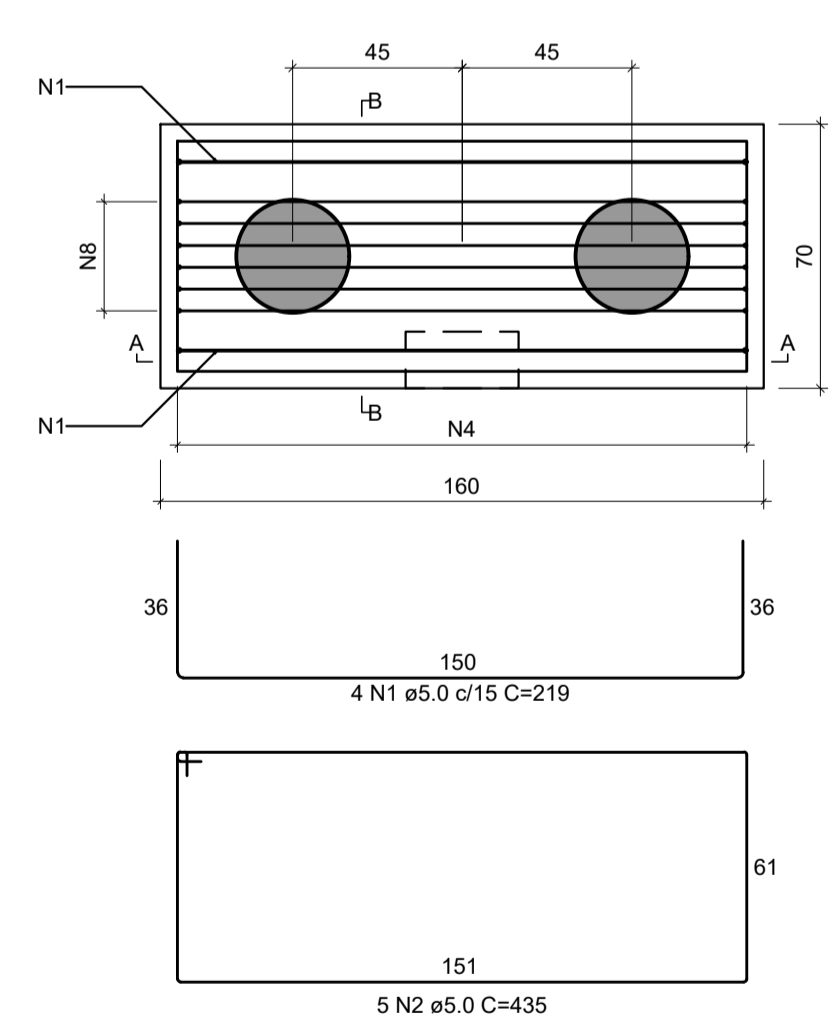

CORTE A-A
ESC 1:20

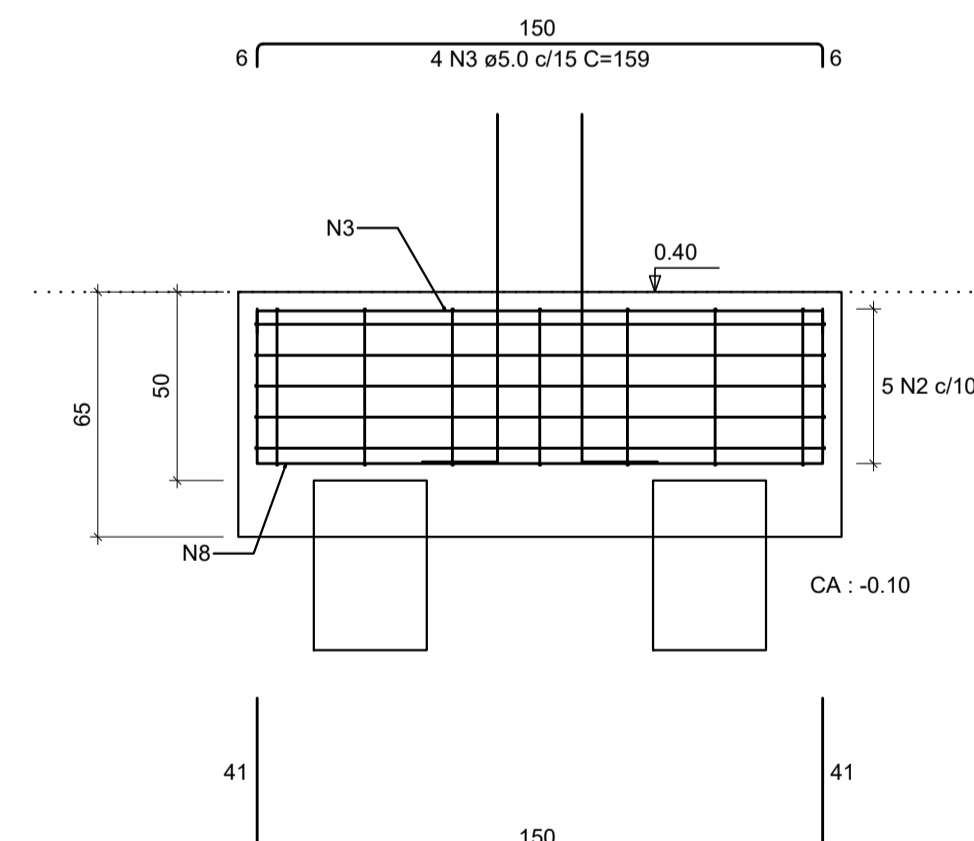

CORTE B-B
ESC 1:20

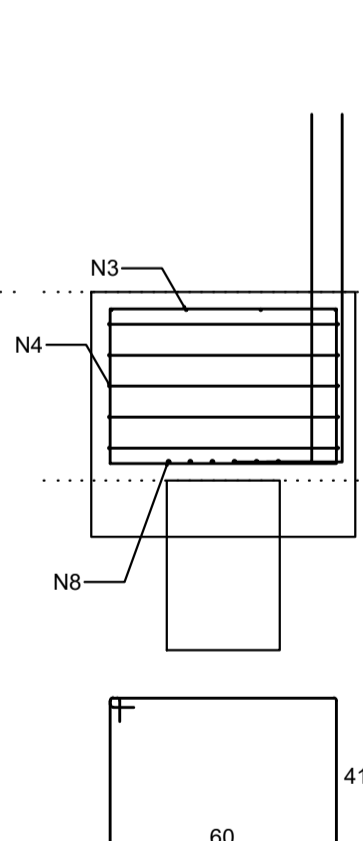

DETALHE DO PILAR
ESC 1:25

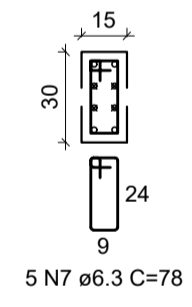

Detalhamento da Fundação (Nível 0,40)

escala 1:50

REV. 00	16/08/19	EMISSÃO INICIAL	DAC
REVISÃO:	DATA :	DESCRIÇÃO:	RESP.:
 Prefeitura Municipal de Pouso Alegre			
 DAC Engenharia Rua Miguel Vienna, nº 81, Sala 12 Bairro Morro Chic CEP: 37500-080 - Itajubá / MG Tel: (35) 3623-5720 www.dacengenharia.com.br	GERÊNCIA DE PROJETOS DENIS DE SOUZA SILVA CREA: MG-127.216/D COORDENAÇÃO DE PROJETOS ALOISIO CAETANO FERREIRA CREA: MG-97.132/D RESPONSÁVEL TÉCNICO ENC. CIVIL FLÁVIA C. BARBOSA CREA: MG-187.842/D PROJETO FLÁVIA CRISTINA BARBOSA DESENHO WILLIAM BARADEL LARI	EMPREENDIMENTO REFORMA E AMPLIAÇÃO DA PEM MONSENHOR MENDONÇA	
ENDEREÇO PRAÇA JOÃO PINHEIRO – BAIRRO CENTRO POUSO ALEGRE – MINAS GERAIS	DISCIPLINA ESTRUTURAL	FASE DO PROJETO EXECUTIVO	
ASSUNTO DETALHAMENTO – NÍVEL BALDRAME DETALHAMENTO DOS BLOCOS	FOLHA Nº. 06/17		
DATA INICIAL 16/08/2019	ESCALA 1:50	REVISÃO R00	ARQUIVO DAC-FMPA-MSR-PE-EST-R00.DWG