

B6=B7=B20=B24=B25=B26=B33  
2xC30  
PLANTA  
ESC 1:20

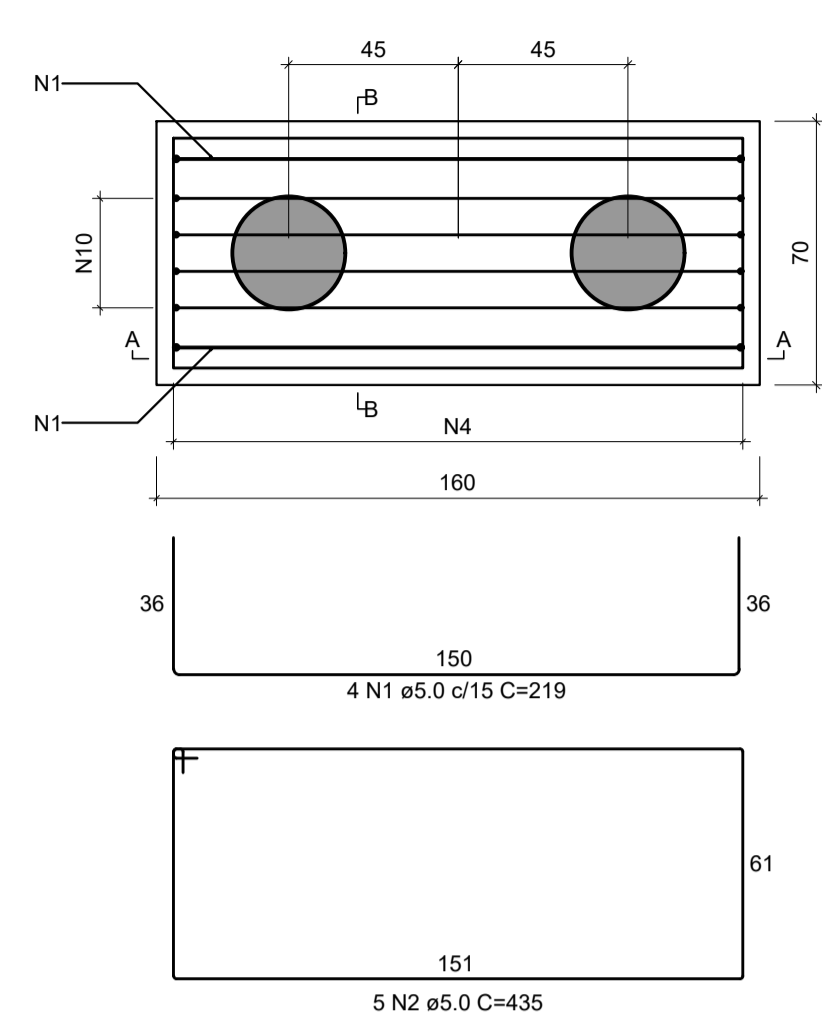

CORTE A-A  
ESC 1:20

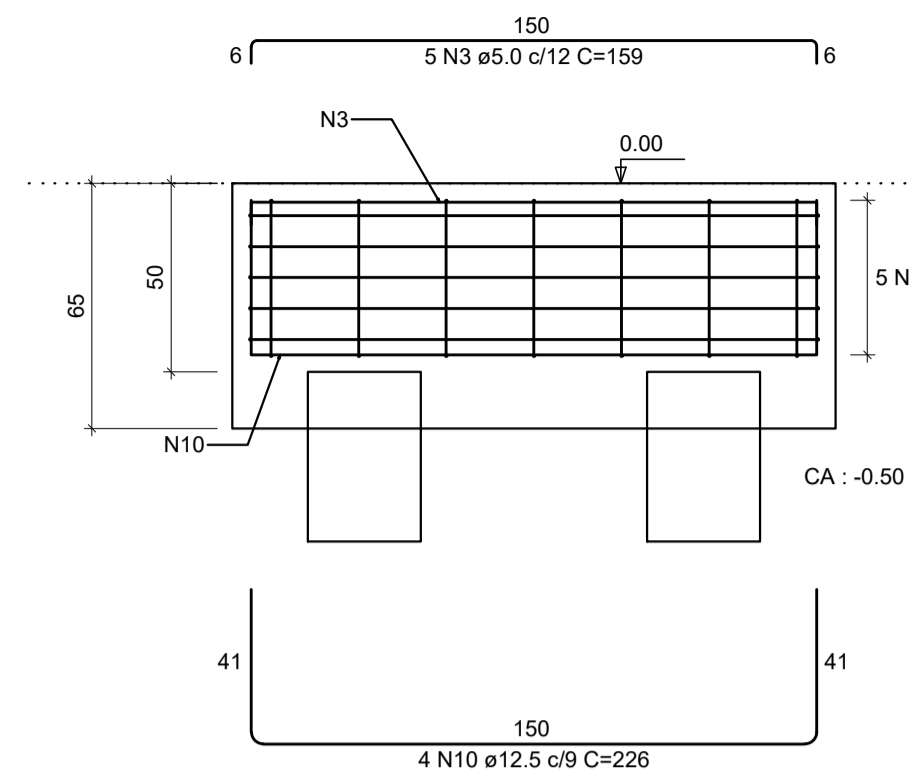

CORTE B-B  
ESC 1:20

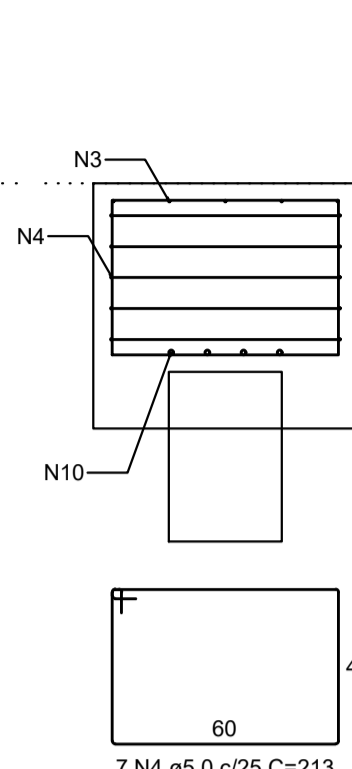

B11  
2xC30  
PLANTA  
ESC 1:20

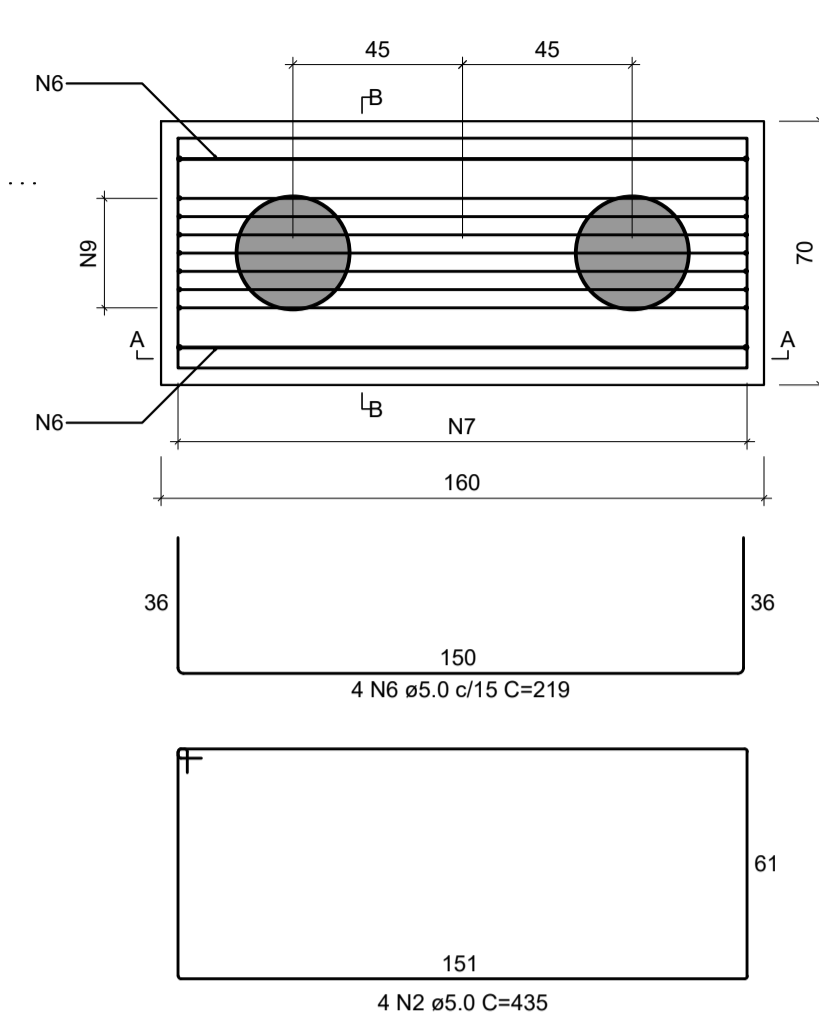

CORTE A-A  
ESC 1:20

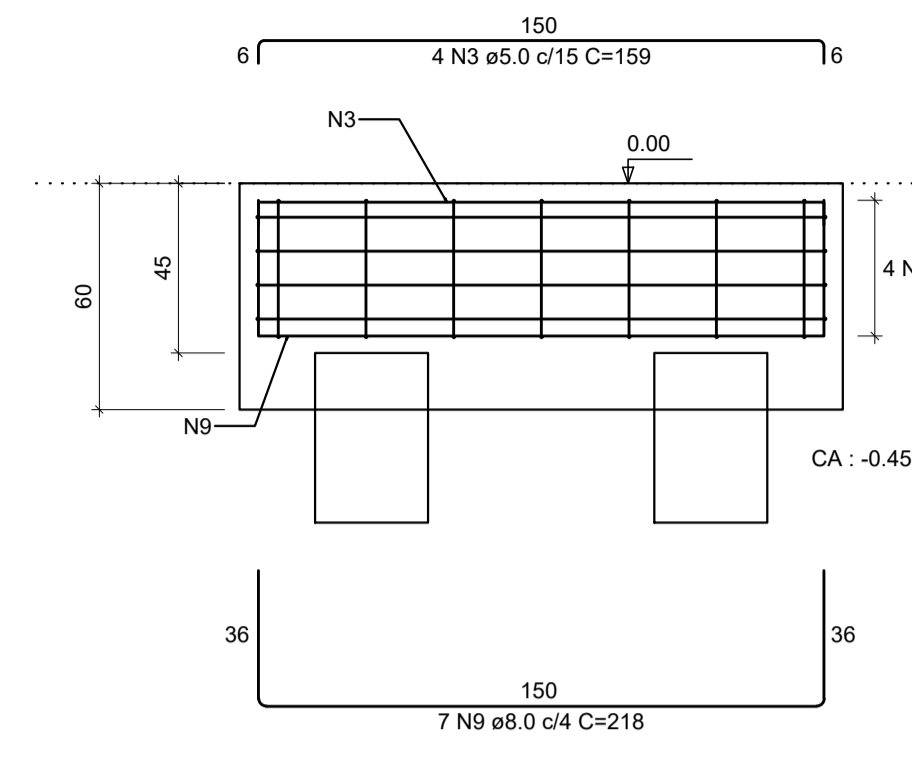

CORTE B-B  
ESC 1:20

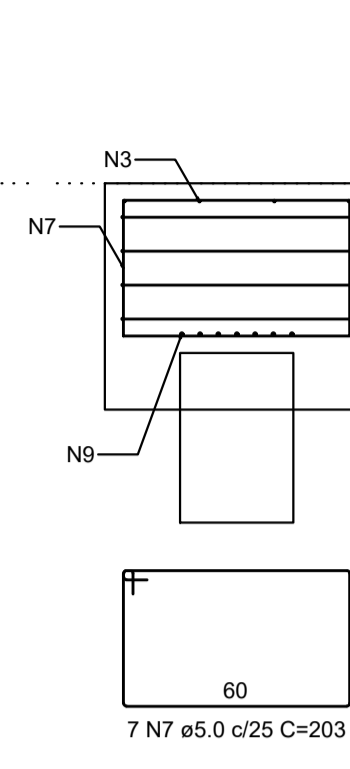

B8=B9=B10=B12=B13=B14=B17=B18=B19=B21  
=B32=B34=B41  
1xC30  
PLANTA  
ESC 1:20

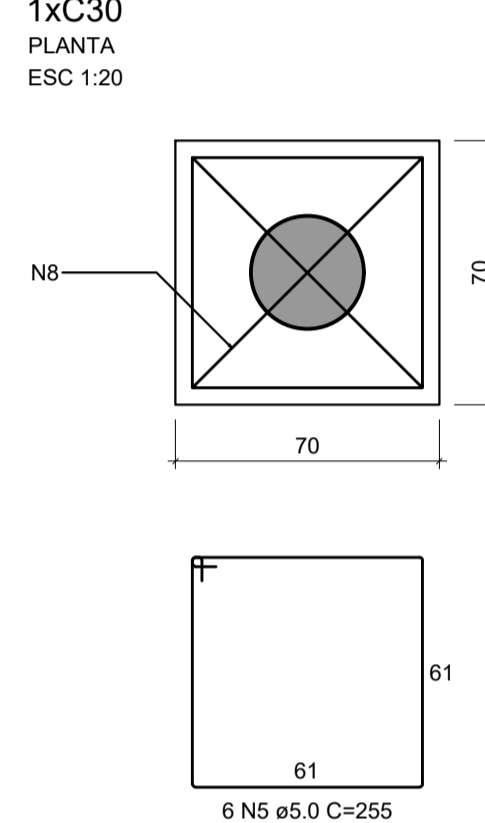

CORTE  
ESC 1:20

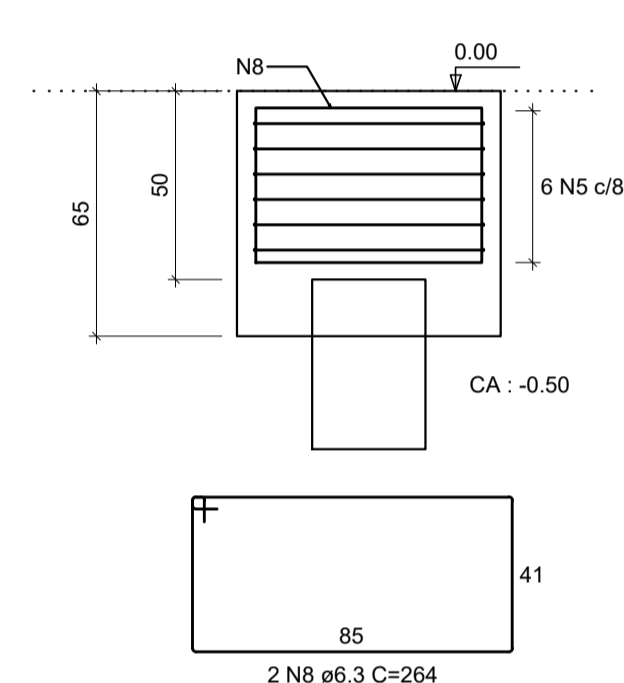

RELAÇÃO DO AÇO

AÇO	N	DIAM (mm)	QUANT	C.UNIT (cm)	C.TOTAL (cm)
CA60	1	5.0	28	219	6132
	2	5.0	39	435	16965
	3	5.0	39	159	6201
	4	5.0	49	213	10437
	5	5.0	78	255	19890
	6	5.0	4	219	876
	7	5.0	7	203	1421
CA50	8	6.3	26	264	6864
	9	8.0	7	218	1526
	10	12.5	28	226	6328

RESUMO DO AÇO

AÇO	DIAM (mm)	C.TOTAL (m)	QUANT + 10% (Barras)	PESO + 10% (kg)
CA50	6.3	68.6	7	18.5
	8.0	15.3	2	6.6
	6.3	63.3	6	67.1
CA60	5.0	619.2	-	105

PESO TOTAL (kg)  
CA50 92.2  
CA60 105

Volume de concreto (C-25) = 9.60 m³  
Área de forma = 47.35 m²

RELAÇÃO DO AÇO

AÇO	N	DIAM (mm)	QUANT	C.UNIT (cm)	C.TOTAL (cm)
CA50	1	6.3	5	26	130
	2	6.3	88	78	6864
	3	6.3	5	88	440
	4	6.3	5	58	290
	5	8.0	4	88	352
	6	10.0	92	102	9384
	7	10.0	4	60	240
	8	12.5	38	110	4180
	9	12.5	10	105	1050

RESUMO DO AÇO

AÇO	DIAM (mm)	C.TOTAL (m)	QUANT + 10% (Barras)	PESO + 10% (kg)
CA50	6.3	77.2	8	20.8
	8.0	3.5	1	1.5
	10.0	96.2	9	65.3
	12.5	52.3	5	55.4

PESO TOTAL (kg)  
CA50 143

Volume de concreto (C-25) = 0.47 m³  
Área de forma = 9.41 m²

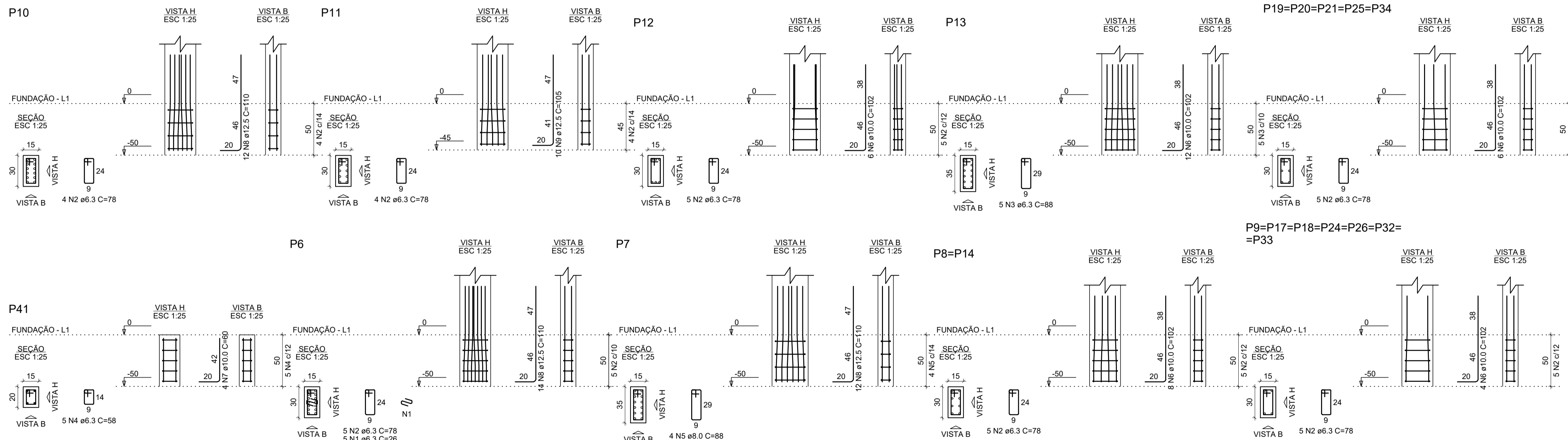

Detalhamento da Fundação (NÍVEL (0,0))

escala 1:50



Prefeitura Municipal de Pouso Alegre

---

<p>PROJETO</p>  <p>Rua Miguel Vianna, nº 81, Sala 12 Bairro Morro Chic CEP: 37500-080 - Itajubá / MG Tel: (35) 3623-5720 www.dacengenharia.com.br</p>	<p>GERÊNCIA DE PROJETOS DENIS DE SOUZA SILVA CREA: MG-127.216/D</p> <p>COORDENAÇÃO DE PROJETOS ALOSIO CAETANO FERREIRA CREA: MG-97.132/D</p> <p>RESPONSÁVEL TÉCNICO ENGR. CIVIL FLÁVIA C. BARBOSA CREA: MG-187.842/D</p> <p>PROJETO FLÁVIA CRISTINA BARBOSA</p> <p>DESENHO WILLIAM BARADEL LARI</p>
--	---

---

**EMPREENDIMENTO**

**REFORMA E AMPLIAÇÃO DA PEM MONSENHOR MENDONÇA**

<p>ENDERÇO PRAÇA JOÃO PINHEIRO – BAIRRO CENTRO POUSO ALEGRE – MINAS GERAIS</p>	<p>DISCIPLINA ESTRUTURAL</p>
<p>ASSUNTO DETALHAMENTO – NÍVEL FUNDAÇÃO DETALHAMENTO DA ARMAÇÃO DOS BLOCOS E ARRANQUES</p>	<p>FASE DO PROJETO EXECUTIVO</p>
<p>FOLHA Nº. <b>05/17</b></p>	

---

DATA INICIAL 16/08/2019	ESCALA 1:50	REVISÃO ROO	ARQUIVO DAC-FMPA-MSR-PE-EST-ROO.DWG
----------------------------	----------------	----------------	--