

Det. Vigas

Escala indicada

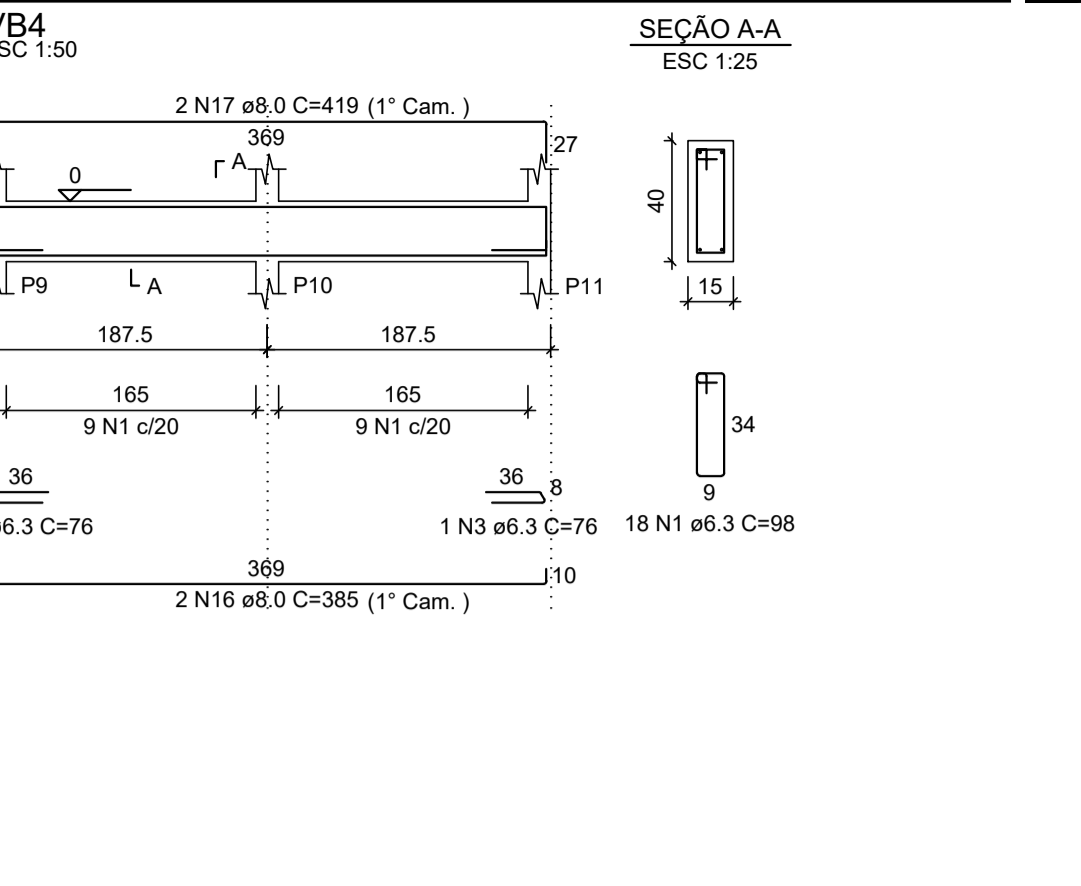

RELAÇÃO DO AÇO				
AÇO	N	DIAM (mm)	QUANT	C.TOTAL (cm)
CA50	1	6.3	283	98
	2	6.3	77	78
	3	6.3	3	228
	4	6.3	148	108
	5	8.0	2	115
	6	8.0	3	285
	7	8.0	2	169
	8	8.0	2	200
	9	8.0	1	342
	10	8.0	2	647
	11	8.0	3	219
	12	8.0	2	82
	13	8.0	2	446
	14	8.0	1	506
	15	8.0	2	690
	16	8.0	2	385
	17	8.0	2	419
	18	8.0	2	194
	19	8.0	3	197
	20	8.0	2	238
	21	8.0	3	247
	22	8.0	2	65
	23	8.0	2	157
	24	8.0	2	160
	25	8.0	4	520
	26	8.0	4	281
	27	8.0	2	144
	28	8.0	2	148
	29	8.0	1	58
	30	8.0	4	262
	31	8.0	1	133
	32	8.0	3	293
	33	8.0	2	260
	34	8.0	2	375
	35	8.0	2	1018
	36	8.0	2	155
	37	8.0	3	305
	38	8.0	2	75
	39	8.0	2	78
	40	8.0	2	523
	41	8.0	4	208
	42	8.0	4	270
	43	8.0	4	271
	44	8.0	4	202
	45	8.0	2	1198
	46	8.0	2	409
	47	8.0	4	1199
	48	8.0	4	421
	49	8.0	4	216
	50	8.0	2	385
	51	8.0	1	205
	52	8.0	1	320
	53	8.0	4	857
	54	8.0	4	87
	55	8.0	3	222
	56	8.0	2	106
	57	8.0	2	895
	58	8.0	3	901
	59	8.0	6	849
	60	8.0	2	210
	61	8.0	2	895
	62	8.0	8	129
	63	8.0	2	233
	64	8.0	1	380
	65	8.0	2	737
	66	8.0	3	245
	67	8.0	2	113
	68	8.0	2	473
	69	8.0	1	538
	70	8.0	2	782
	71	8.0	2	874
	72	8.0	2	275
	73	8.0	3	274
	74	8.0	3	101
	75	8.0	2	612
	76	8.0	1	616
	77	8.0	4	900
	78	8.0	2	213
	79	8.0	3	224
	80	8.0	2	491
	81	8.0	1	556
	82	10.0	1	103
	83	10.0	2	65
	84	10.0	1	186
	85	10.0	1	380
	86	10.0	2	390
	87	10.0	2	75
	88	10.0	2	118
	89	10.0	30	96
	90	10.0	2	557
	91	10.0	8	567
	92	10.0	4	129
	93	12.5	6	104

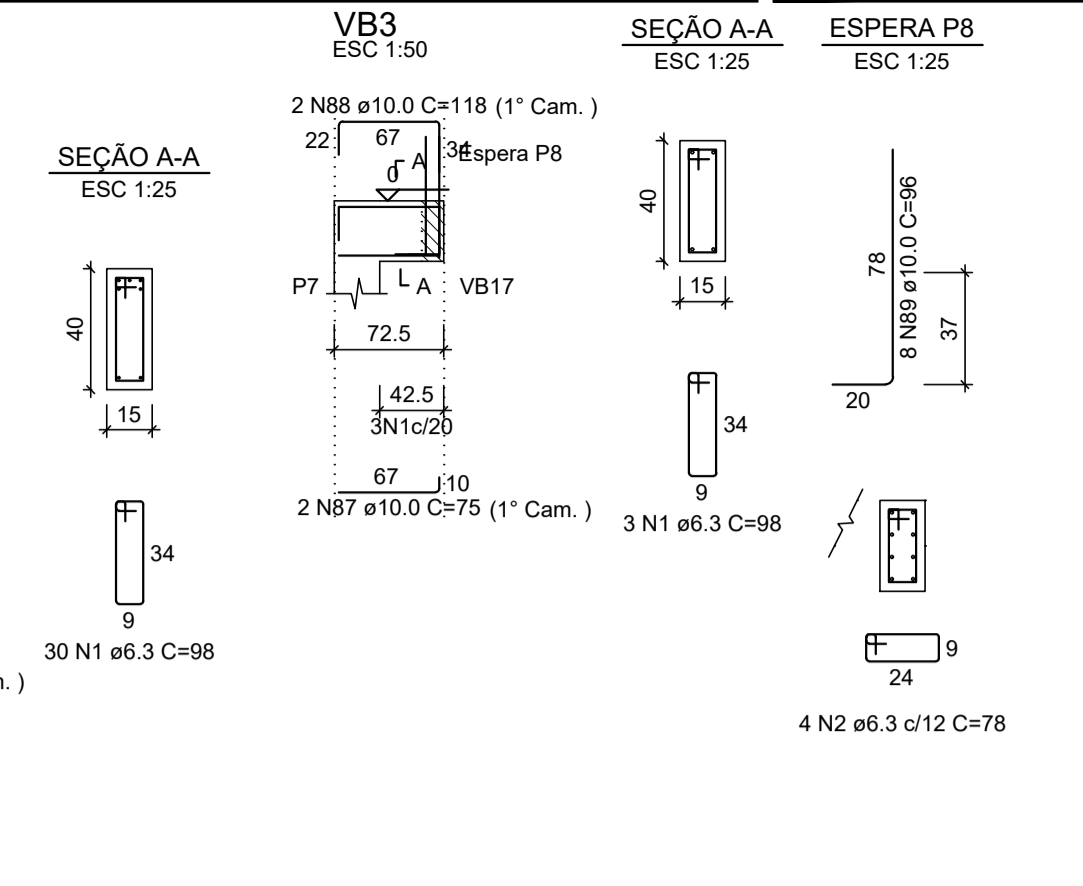
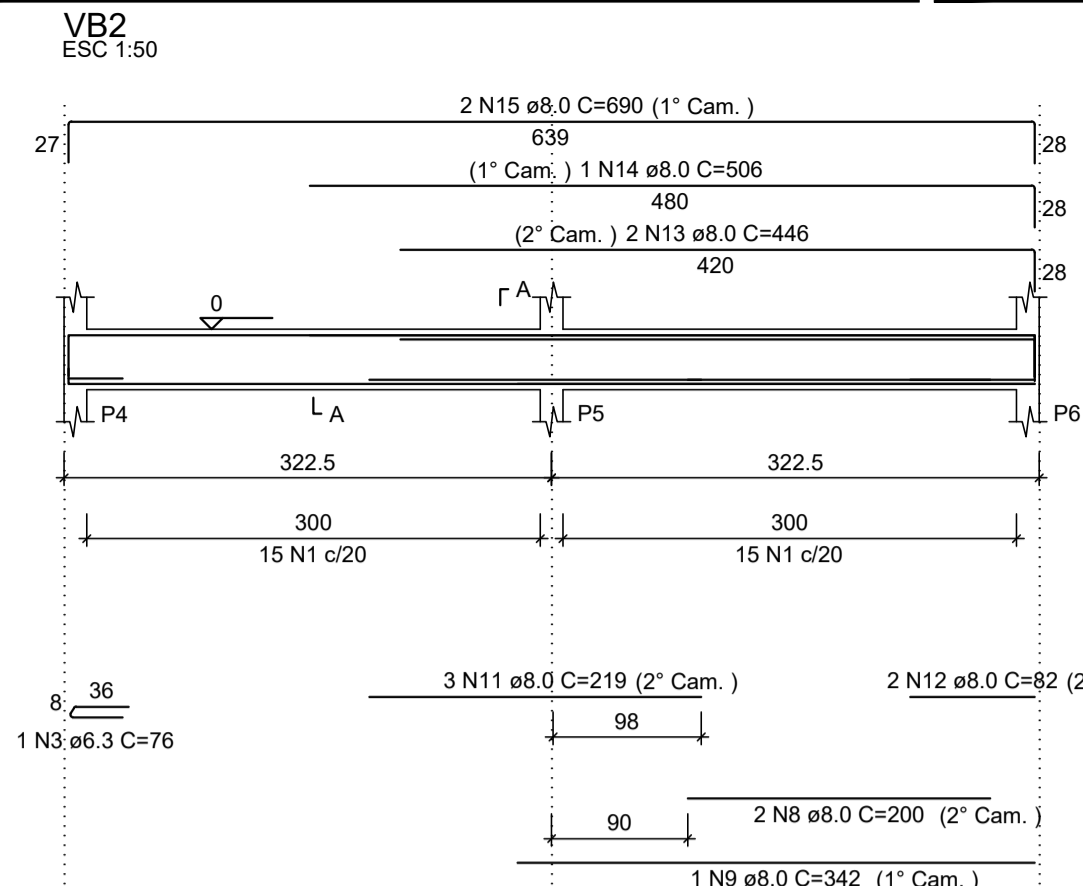
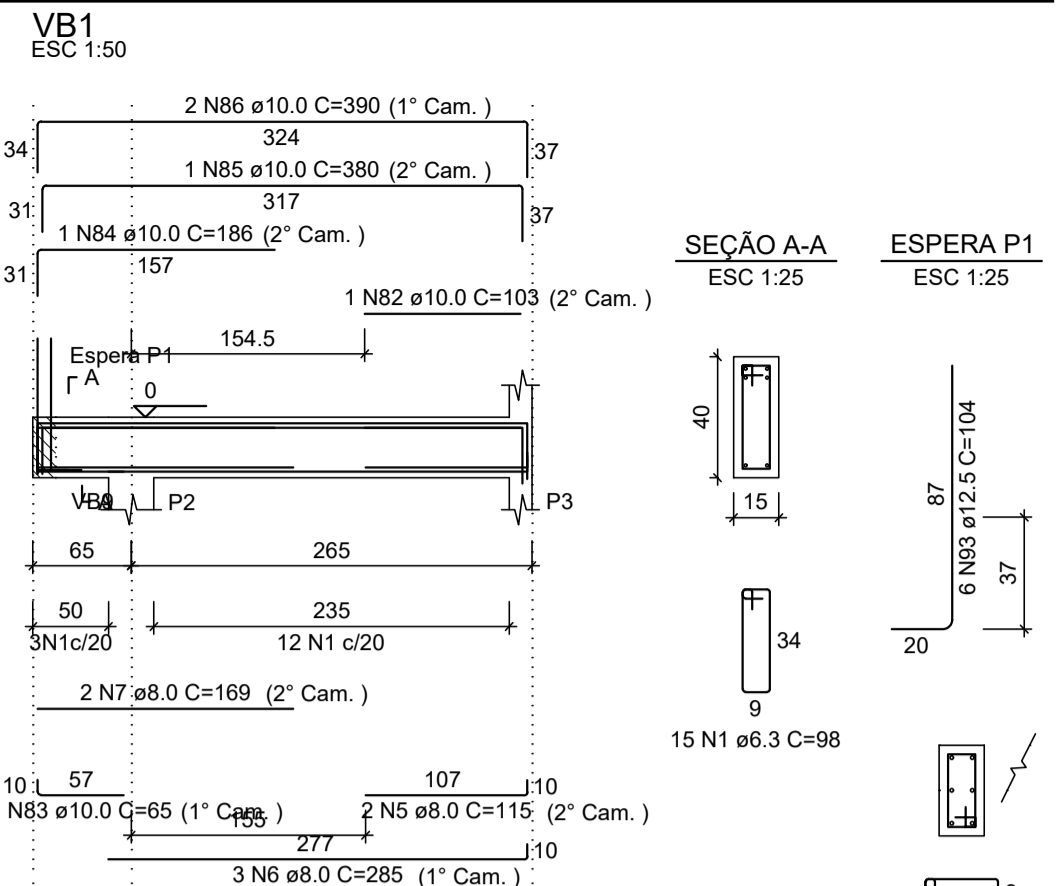
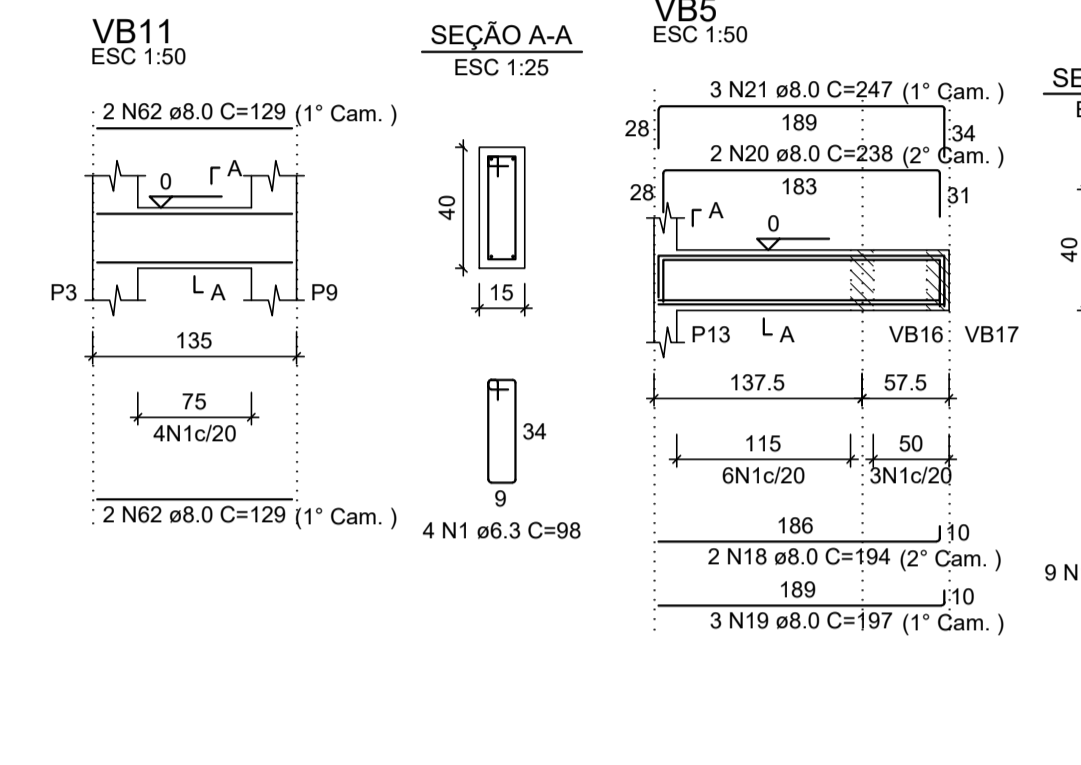
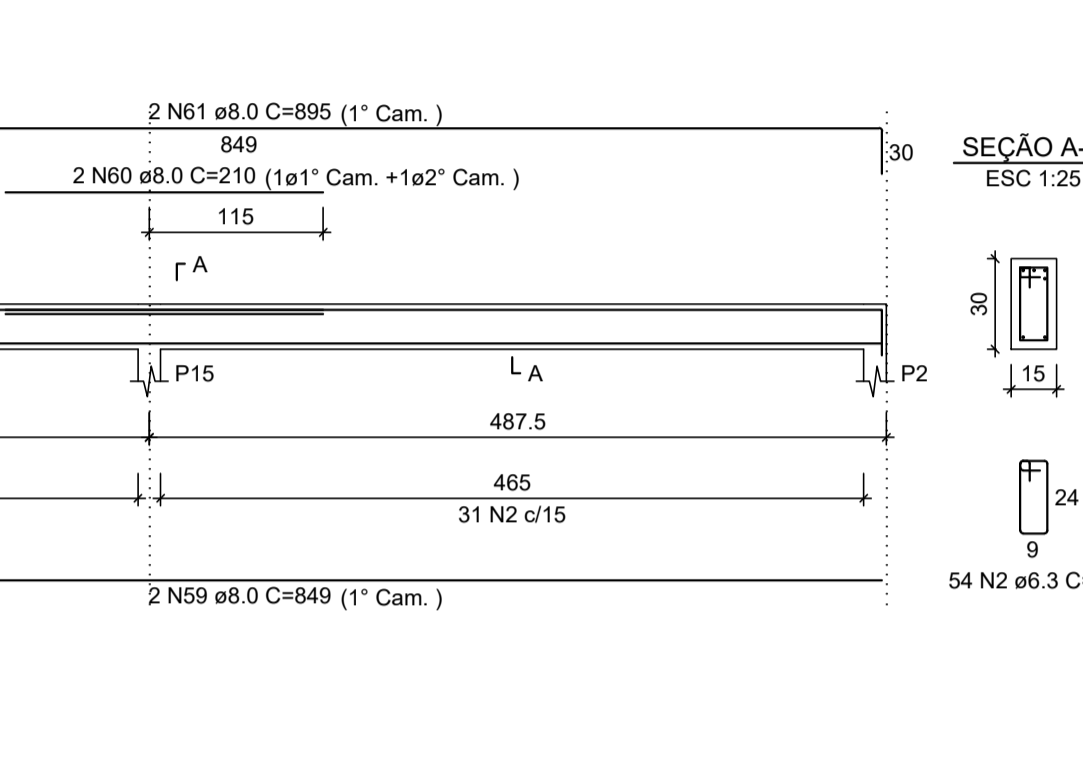
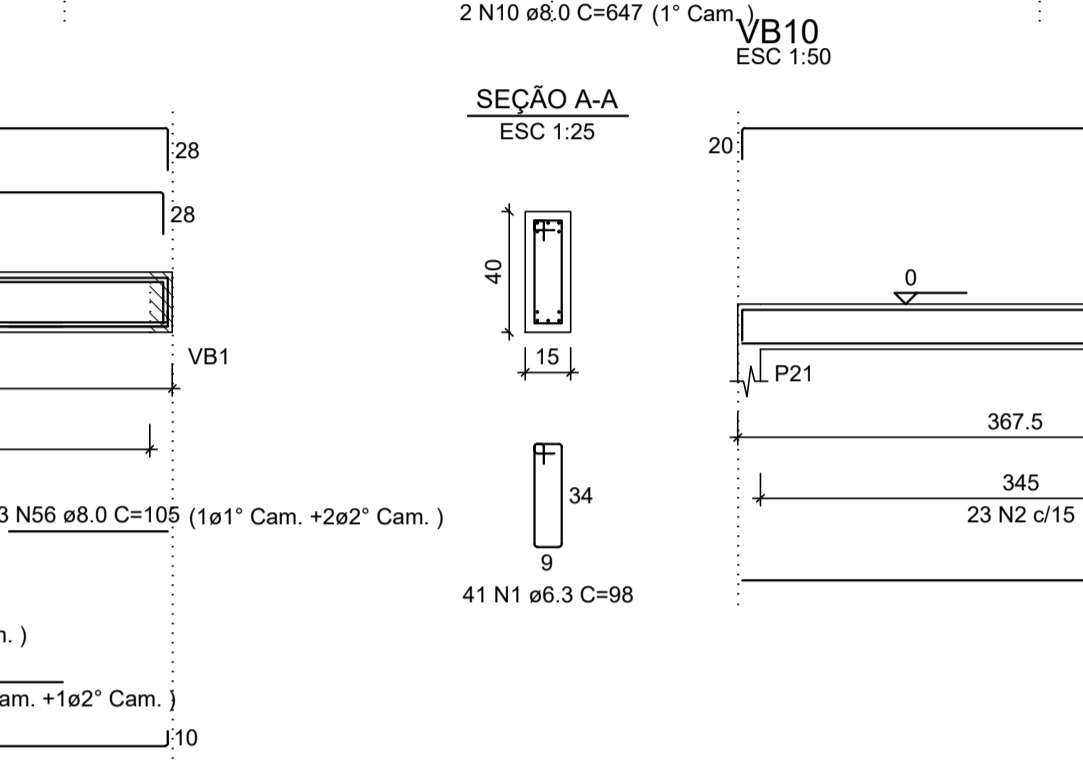
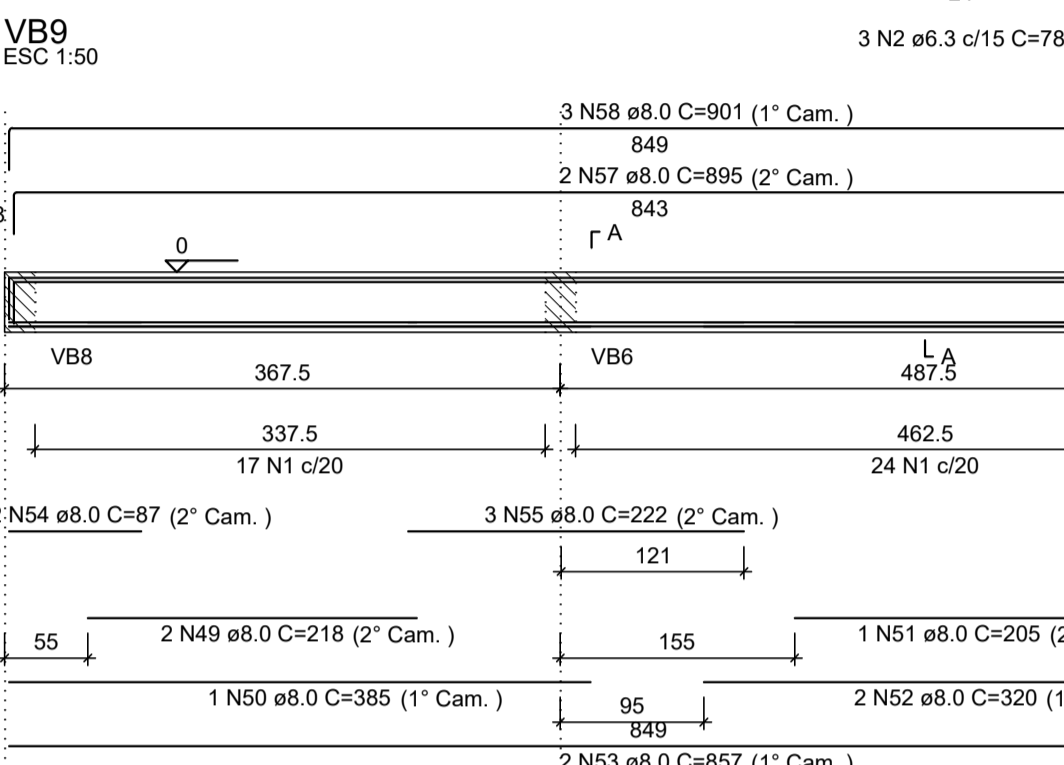

AÇO	N	DIAM (mm)	QUANT	C.TOTAL (cm)
CA50	1	6.3	283	98
	2	6.3	77	78
	3	6.3	3	228
	4	6.3	148	108
	5	8.0	2	115
	6	8.0	3	285
	7	8.0	2	169
	8	8.0	2	200
	9	8.0	1	342
	10	8.0	2	647
	11	8.0	3	219
	12	8.0	2	82
	13	8.0	2	446
	14	8.0	1	506
	15	8.0	2	690
	16	8.0	2	385
	17	8.0	2	419
	18	8.0	2	194
	19	8.0	3	197
	20	8.0	2	238
	21	8.0	3	247
	22	8.0	2	65
	23	8.0	2	157
	24	8.0	2	160
	25	8.0	4	520
	26	8.0	4	281
	27	8.0	2	144
	28	8.0	2	148
	29	8.0	1	58
	30	8.0	4	262
	31	8.0	1	133
	32	8.0	3	293
	33	8.0	2	260
	34	8.0	2	375
	35	8.0	2	1018
	36	8.0	2	155
	37	8.0	3	305
	38	8.0	2	75
	39	8.0	2	78
	40	8.0	2	523
	41	8.0	4	208
	42	8.0	4	270
	43	8.0	4	271
	44	8.0	4	202
	45	8.0	2	1198
	46	8.0	2	409
	47	8.0	4	1199
	48	8.0	4	421
	49	8.0	4	216
	50	8.0	2	385
	51	8.0	1	205
	52	8.0	1	320
	53	8.0	4	857
	54	8.0	4	87
	55	8.0	3	222
	56	8.0	2	106
	57	8.0	2	895
	58	8.0	3	901
	59	8.0	6	849
	60	8.0	2	210
	61	8.0	2	895
	62	8.0	8	129
	63	8.0	2	233
	64	8.0	1	380
	65	8.0	2	737
	66	8.0	3	245
	67	8.0	2	113
	68	8.0	2	473
	69	8.0	1	538
	70	8.0	2	782
	71	8.0	2	874
	72	8.0	2	275
	73	8.0	3	274
	74	8.0	3	101
	75	8.0	2	612
	76	8.0	1	616
	77	8.0	4	900
	78	8.0	2	213
	79	8.0	3	224
	80	8.0	2	491
	81	8.0	1	556
	82	10.0	1	103
	83	10.0	2	65
	84	10.0	1	186
	85	10.0	1	380
	86	10.0	2	390
	87	10.0	2	75
	88	10.0	2	118
	89	10.0	30	96
	90	10.0	2	557
	91	10.0	8	567
	92	10.0	4	129
	93	12.5	6	104

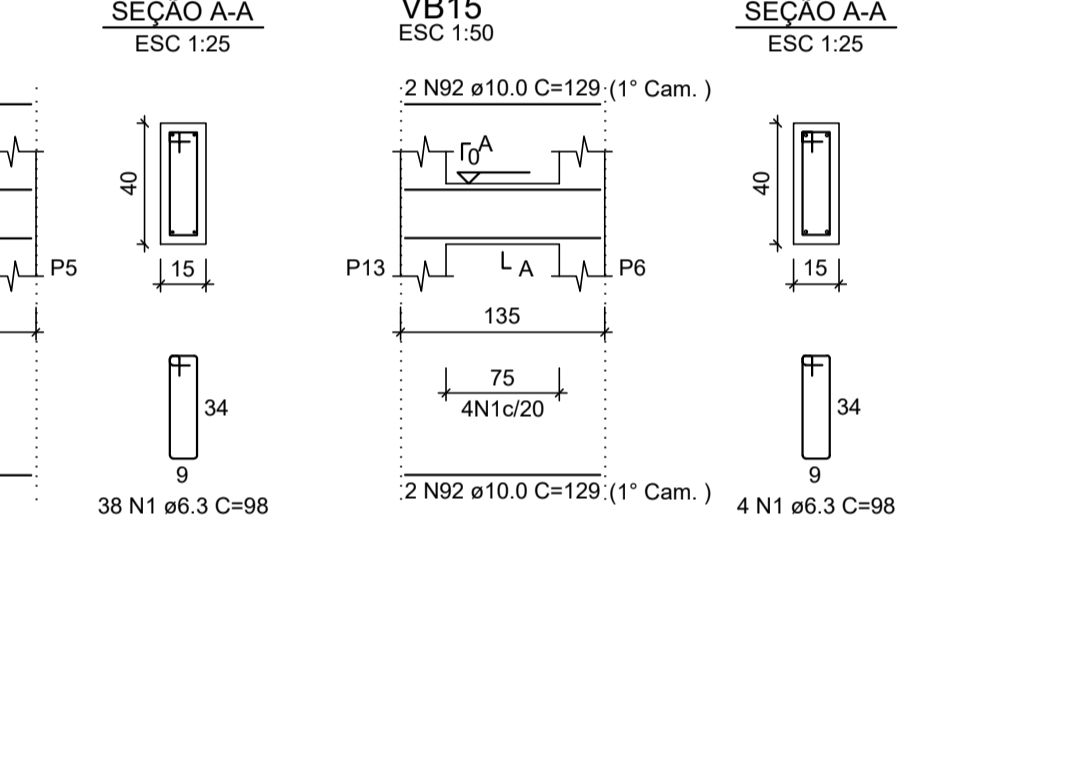
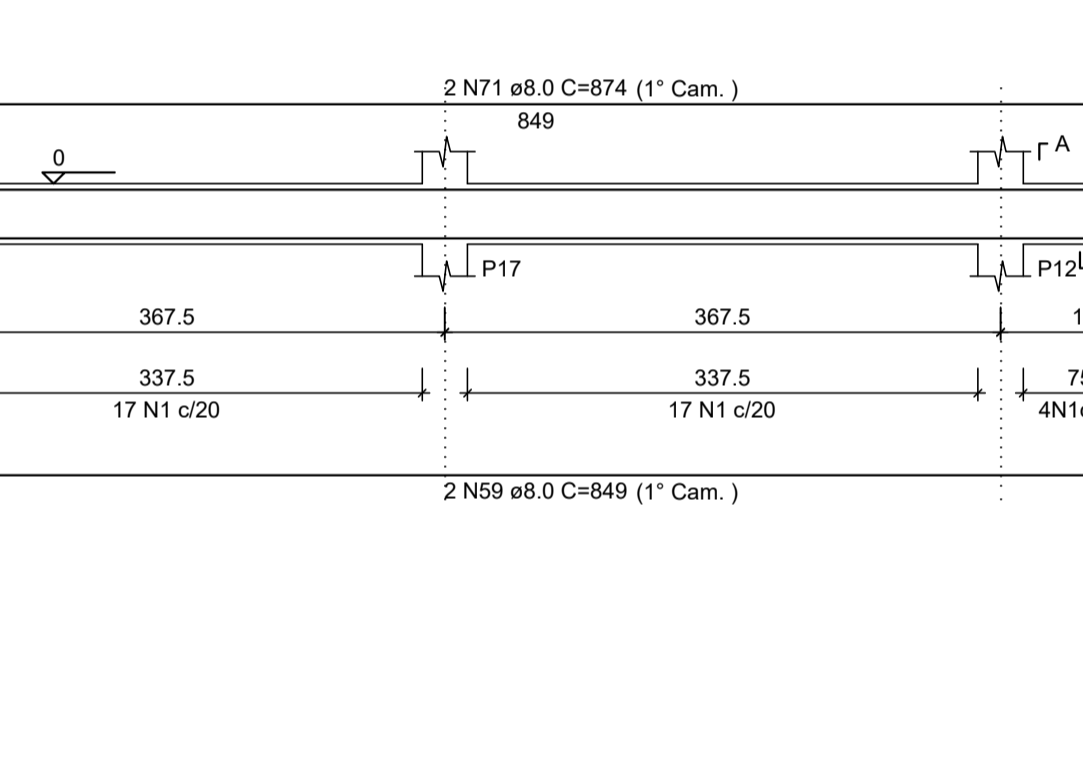
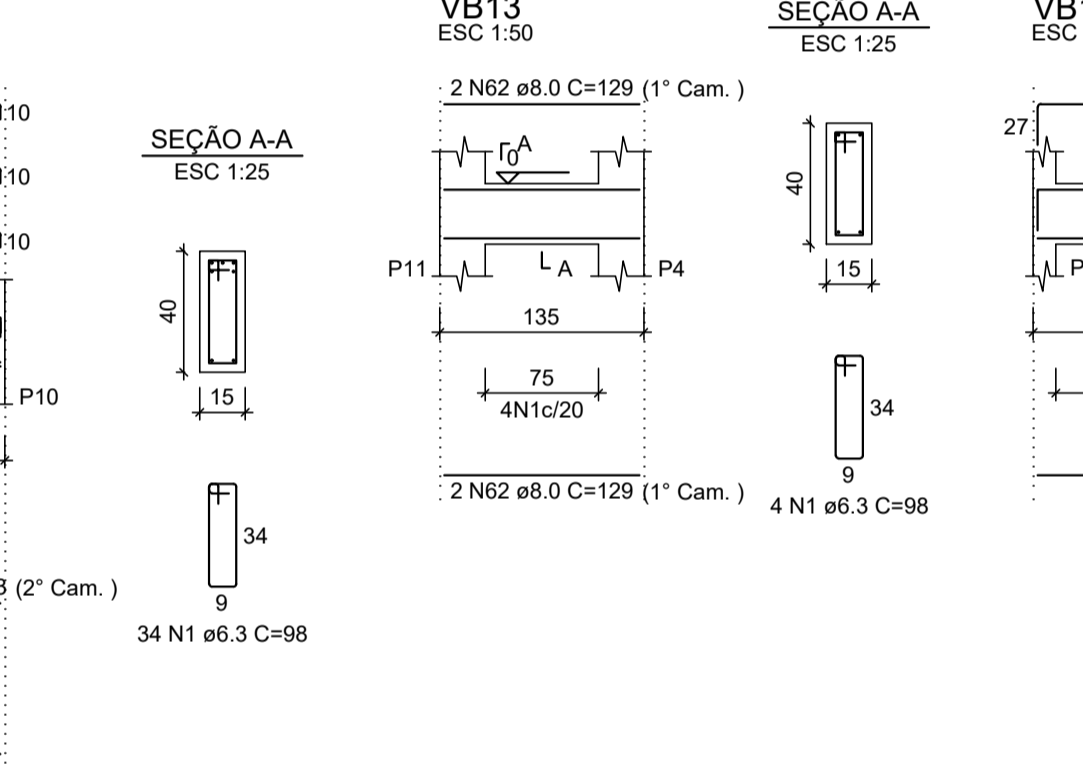
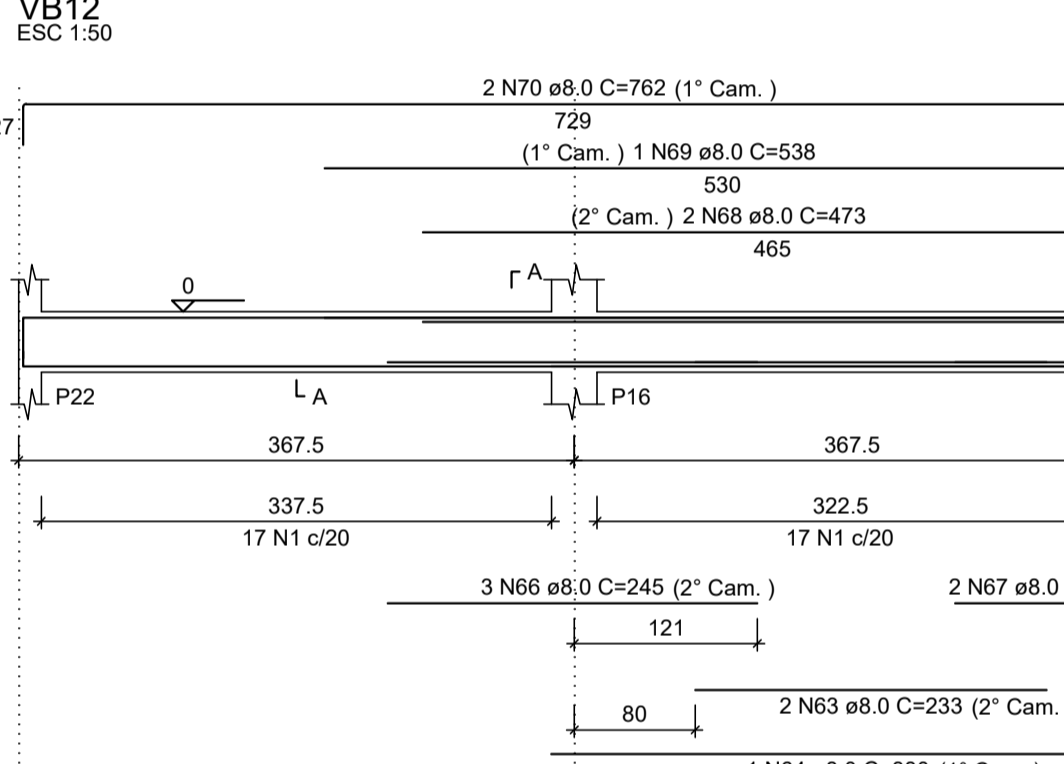

AÇO	N	DIAM (mm)	QUANT	C.TOTAL (cm)
CA50	1	6.3	283	98
	2	6.3	77	78
	3	6.3	3	228
	4	6.3	148	108
	5	8.0	2	115
	6	8.0	3	285
	7	8.0	2	169
	8	8.0	2	200
	9	8.0	1	342
	10	8.0	2	647
	11	8.0	3	219
	12	8.0	2	82
	13	8.0	2	446
	14	8.0	1	506
	15	8.0	2	690
	16	8.0	2	385
	17	8.0	2	419
	18	8.0	2	194
	19	8.0	3	197
	20	8.0	2	238
	21	8.0	3	247
	22	8.0	2	65
	23	8.0	2	157
	24	8.0	2	160
	25	8.0	4	520
	26	8.0	4	281
	27	8.0	2	144
	28	8.0	2	148
	29	8.0	1	58
	30	8.0	4	262
	31	8.0	1	133
	32	8.0	3	293
	33	8.0	2	260
	34	8.0	2	375
	35	8.0	2	1018
	36	8.0	2	155
	37	8.0	3	305
	38	8.0	2	75
	39	8.0	2	78
	40	8.0	2	523
	41	8.0	4	208
	42	8.0	4	270
	43	8.0	4	271
	44	8.0	4	202
	45	8.0	2	1198
	46	8.0	2	409
	47	8.0	4	1199
	48	8.0	4	421
	49	8.0	4	216
	50	8.0	2	385
	51	8.0	1	205
	52	8.0	1	320
	53	8.0	4	857
	54	8.0	4	87
	55	8.0	3	222
	56	8.0	2	106
	57	8.0	2	895
	58	8.0	3	901
	59	8.0	6	849
	60	8.0	2	210
	61	8.0	2	895
	62	8.0	8	129
	63	8.0	2	233
	64	8.0	1	380
	65	8.0	2	737
	66	8.0	3	245
	67	8.0	2	113
	68	8.0	2	473
	69	8.0	1	538
	70	8.0	2	782
	71	8.0	2	874
	72	8.0	2	275
	73	8.0	3	274
	74	8.0	3	101
	75	8.0	2	612
	76	8.0	1	616
	77	8.0	4	900
	78	8.0	2	213
	79	8.0	3	224
	80	8.0	2	491
	81	8.0	1	556
	82	10.0	1	103
	83	10.0	2	65
	84	10.0	1	186
	85	10.0	1	380
	86	10.0	2	390
	87	10.0	2	75
	88	10.0	2	118
	89	10.0	30	96
	90	10.0	2	557
	91	10.0	8	567
	92	10.0	4	129
	93	12.5	6	104

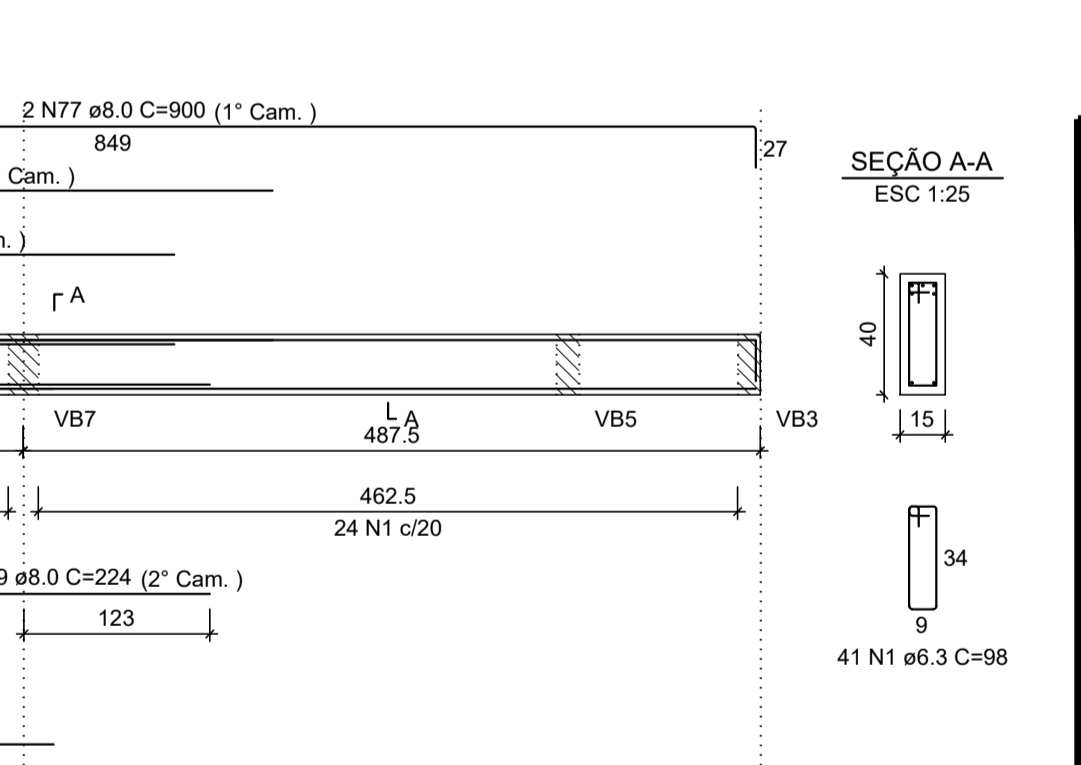
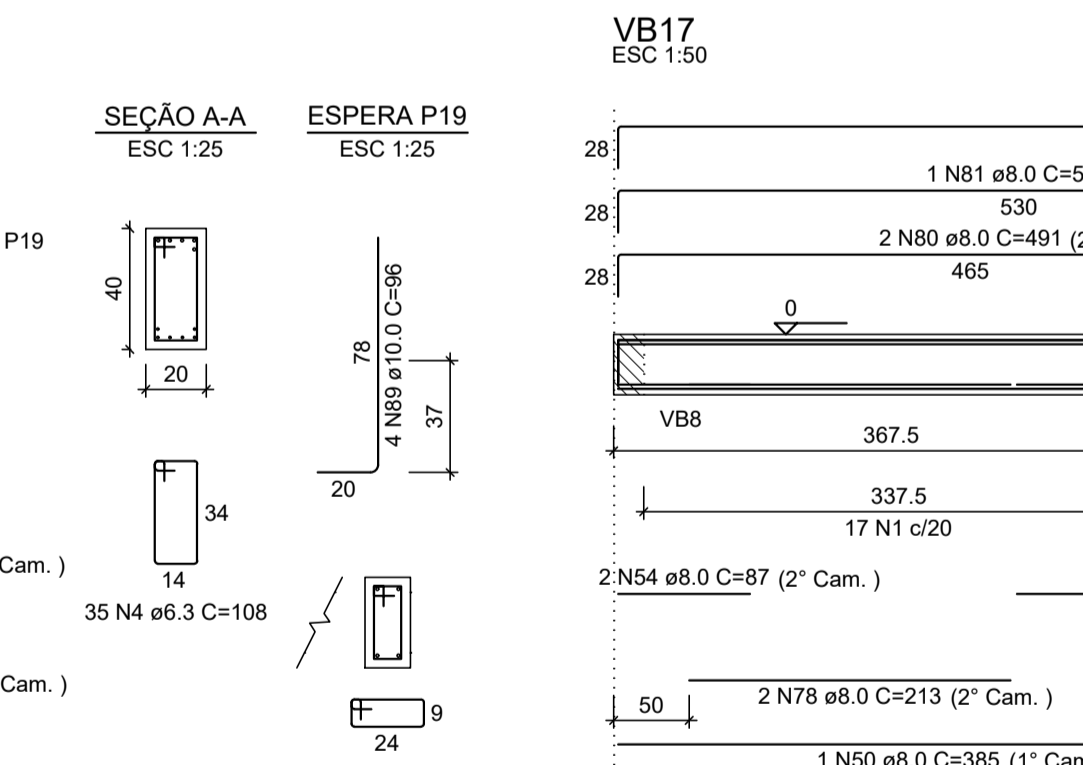
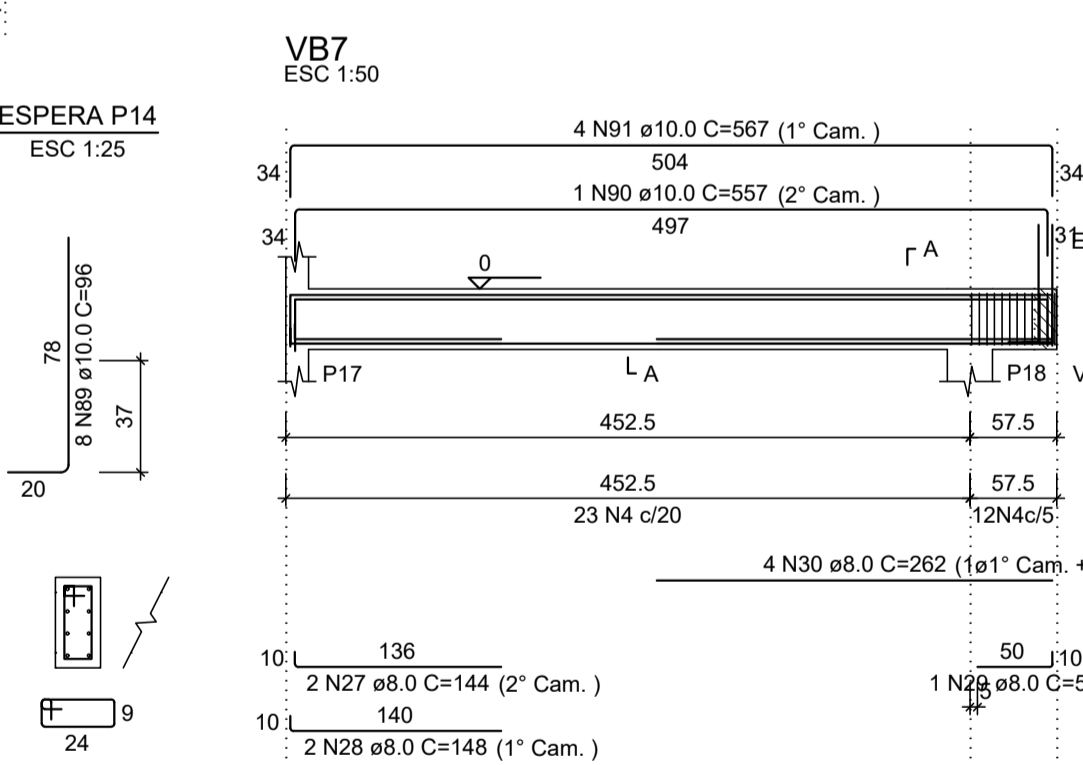
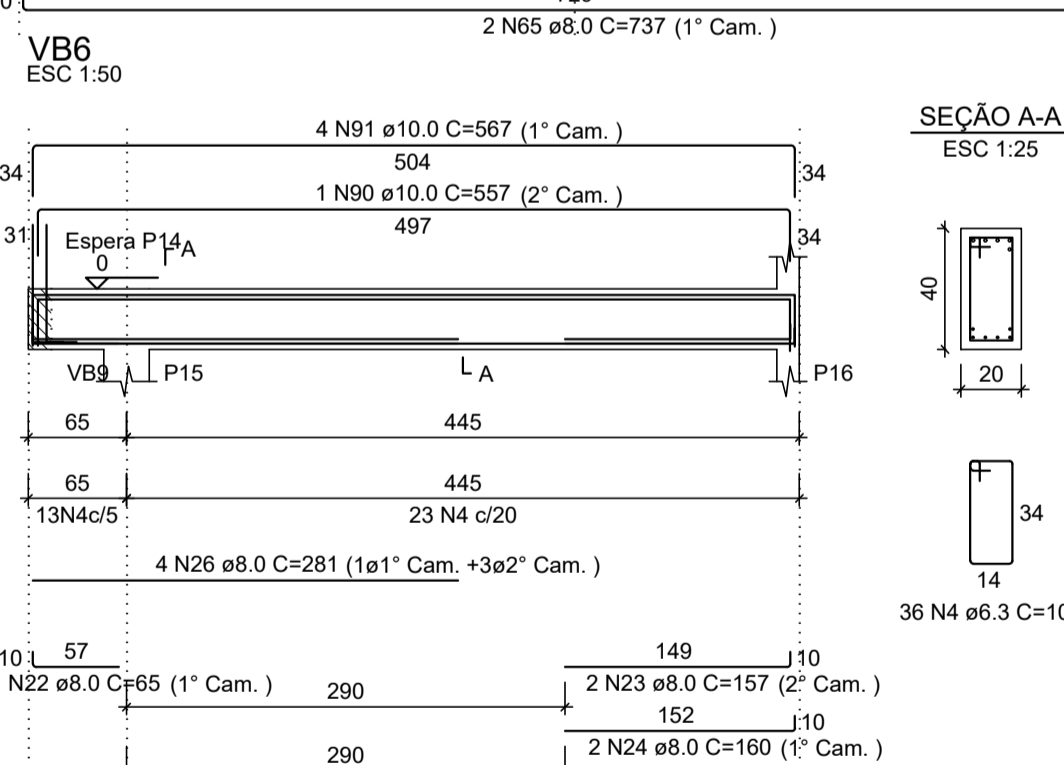

AÇO	N	DIAM (mm)	QUANT	C.TOTAL (cm)
CA50	1	6.3	283	98
	2	6.3	77	78
	3	6.3	3	228
	4	6.3	148	108