

PROJETO ESTRUTURAL - CEMAPA

ESCALA INDICADA

P14=P15=P20=P24=  
=P25=P26=P32=P41=  
=P42=P45=P46=P47=  
=P49=P50=P51=P56=  
=P57=P60=P62=P66=  
=P76=P77=P78=P79=  
=P80=P81=P82=P83=  
=P91=P92=P94=P95=  
=P96=P97=P98=P101=  
=P102=P103=P106=  
=P107=P121

P16=P27=P34=P35=  
=P65=P67=P72=P73=  
=P86=P90=P93=P105=  
=P109=P115=P116=  
=P118=P125=P131=  
=P132

P29=P31

P3

P30

P37=P68=P71

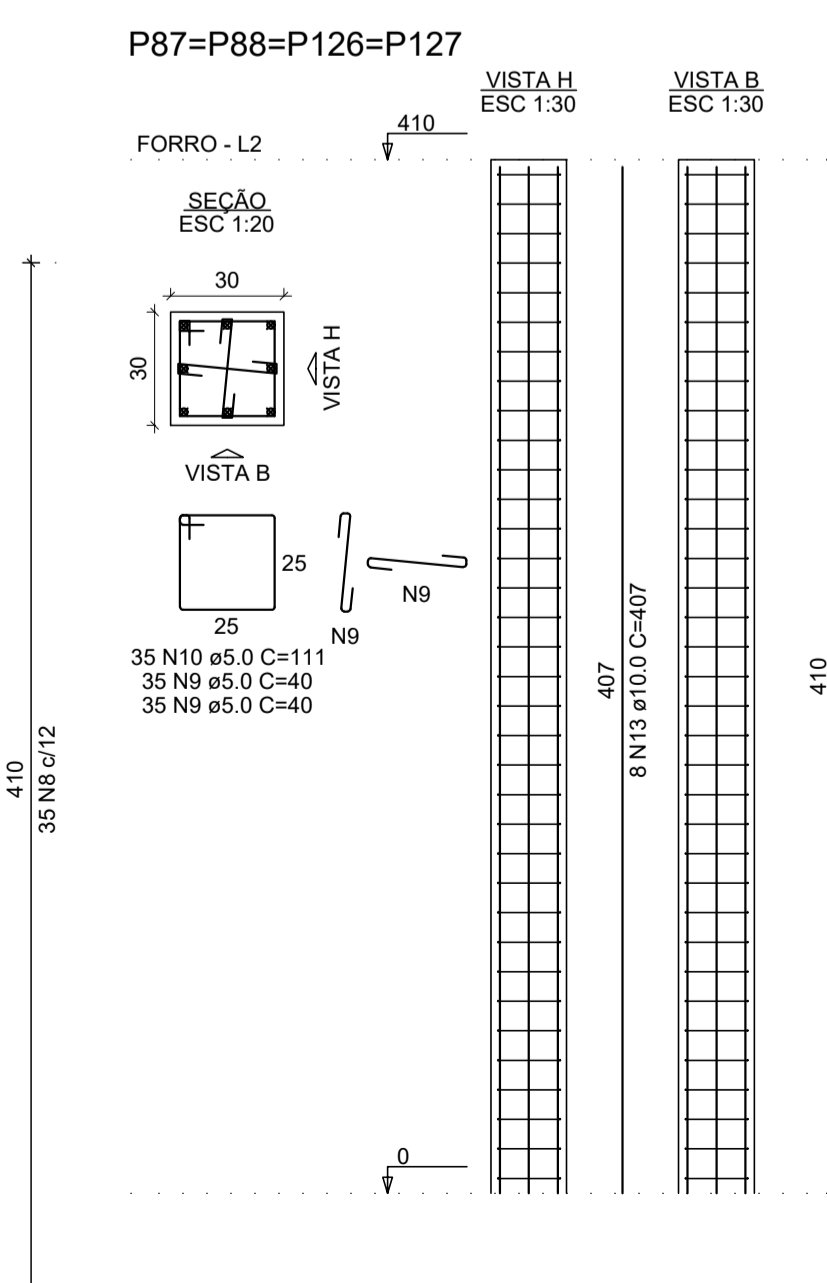
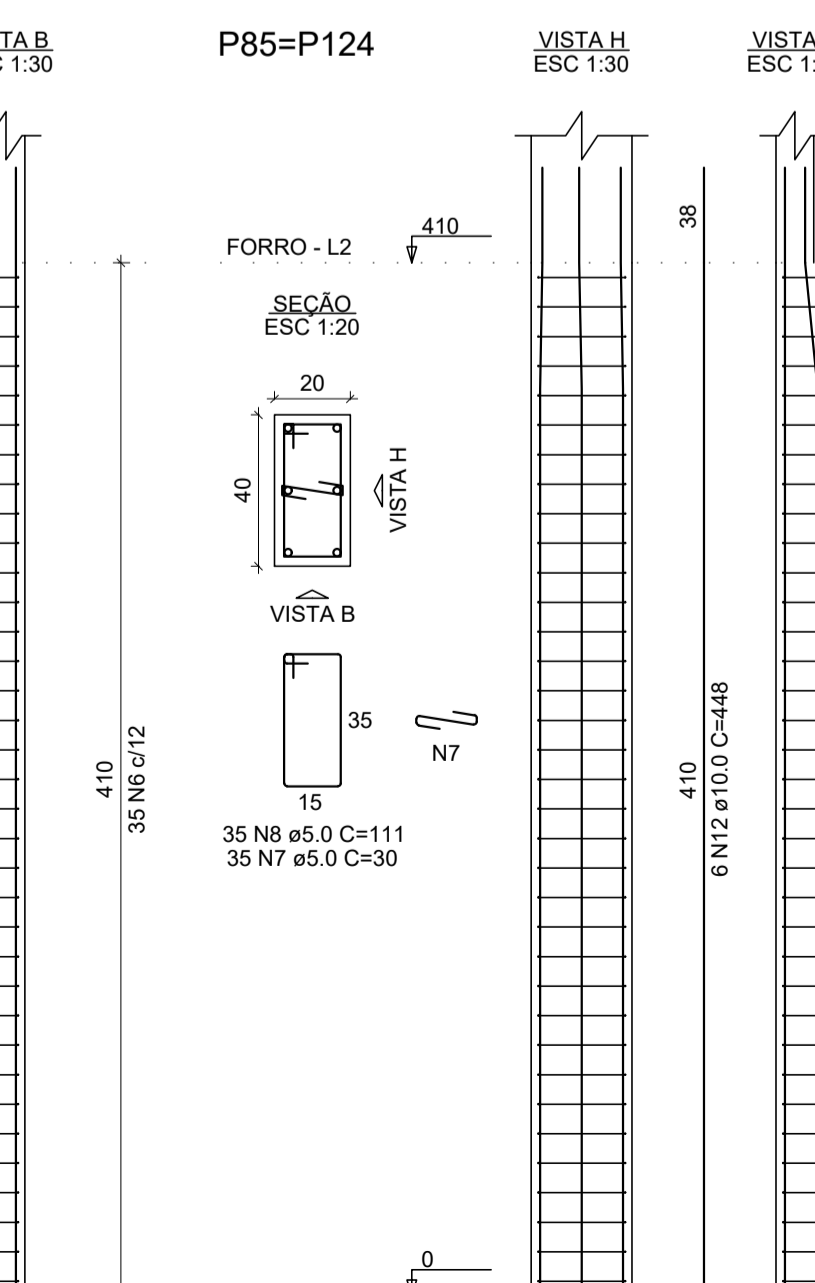
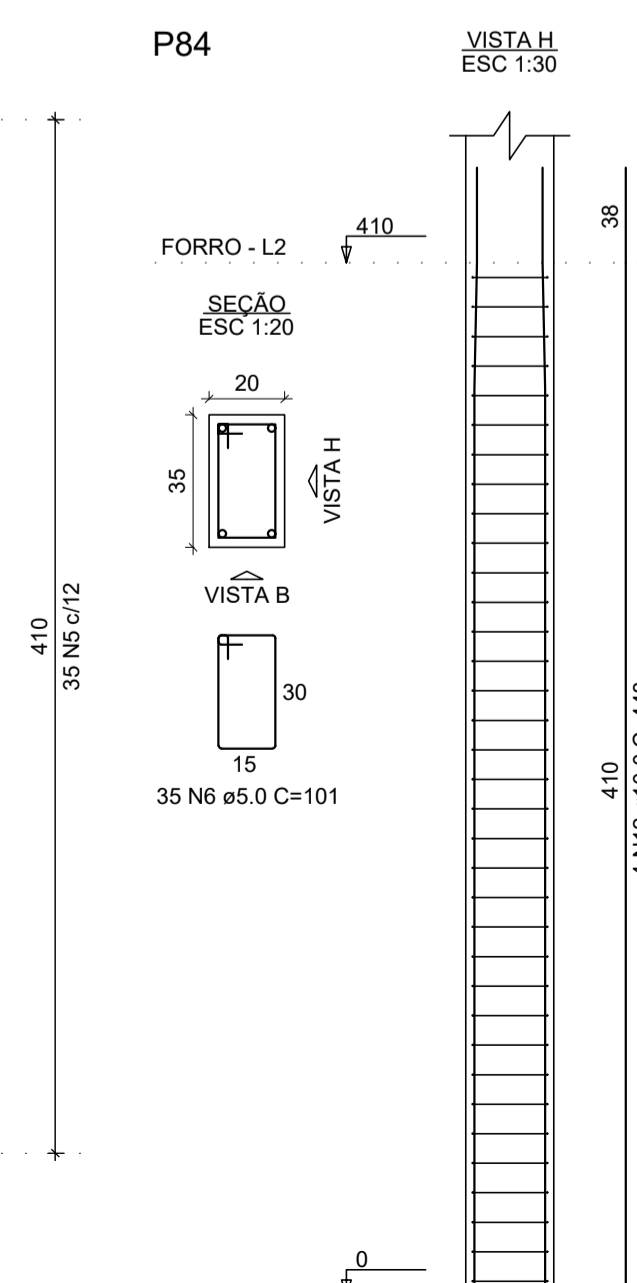
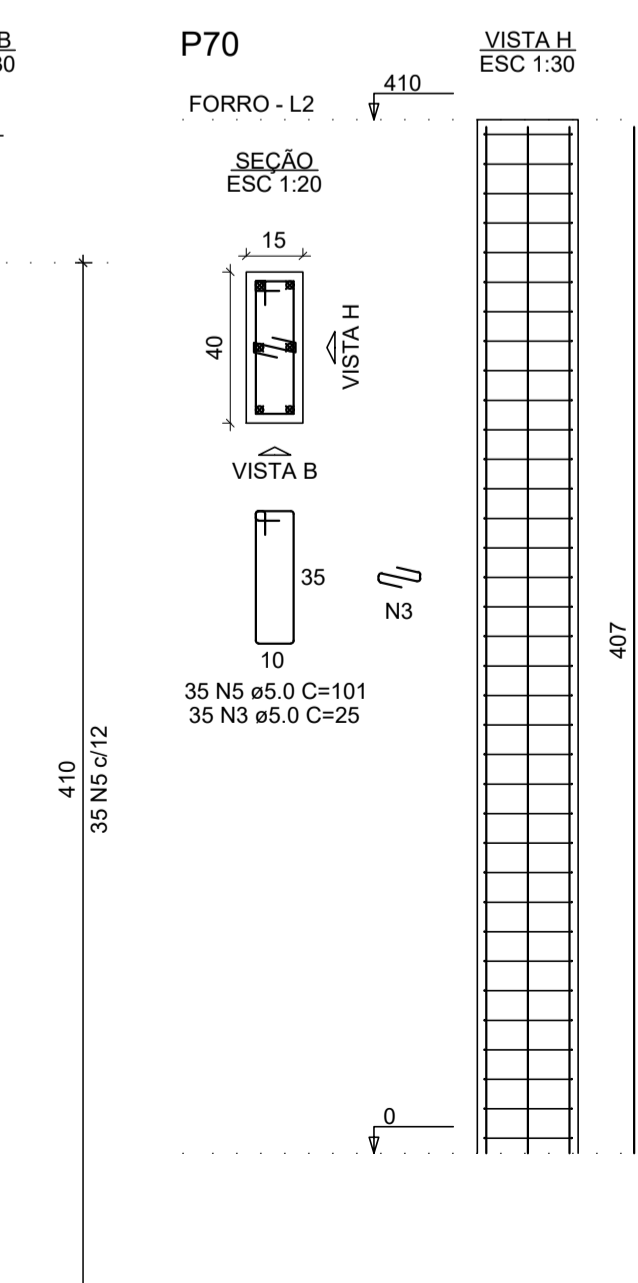
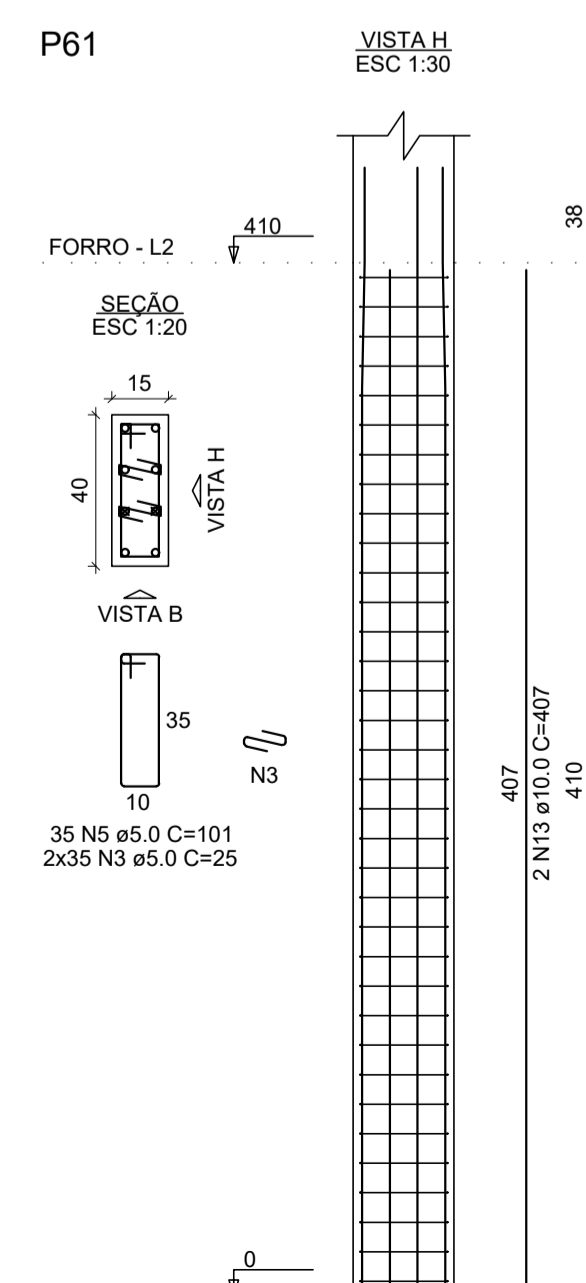
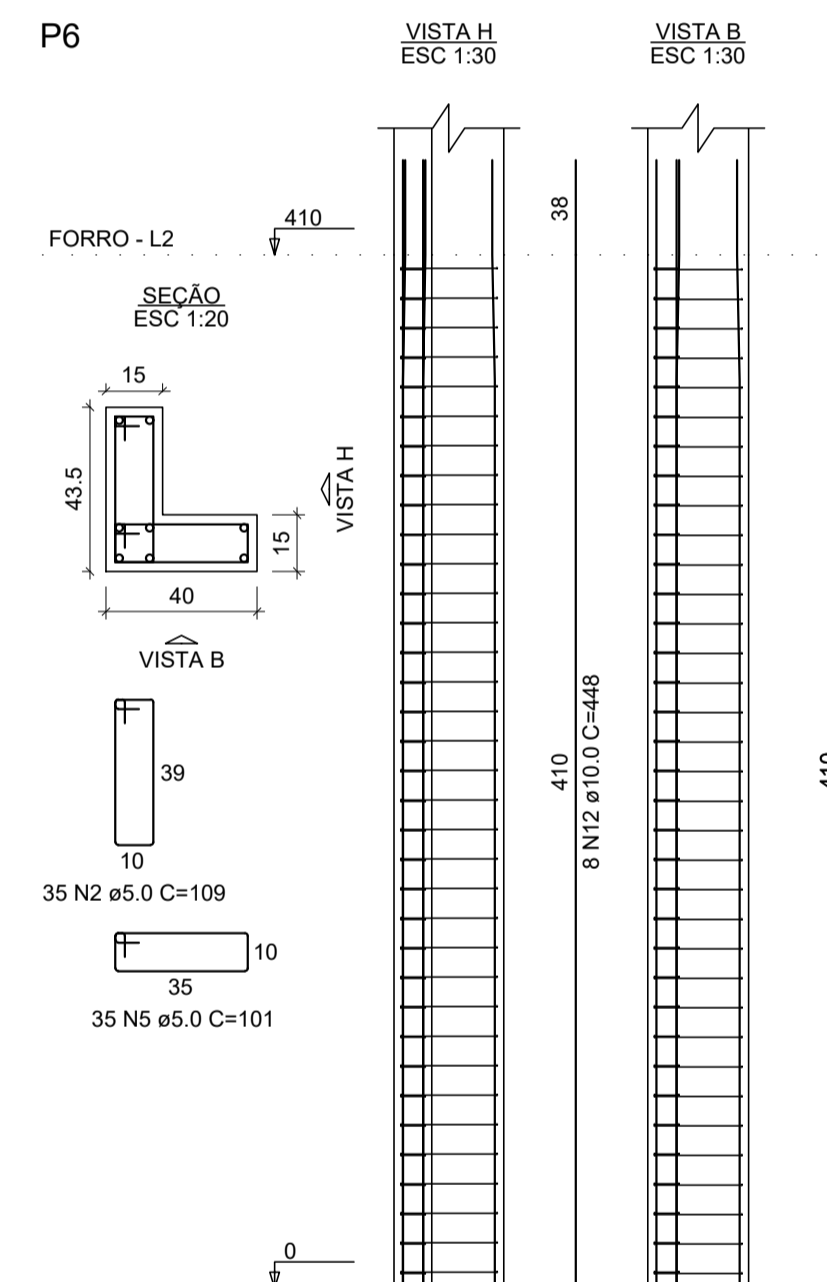
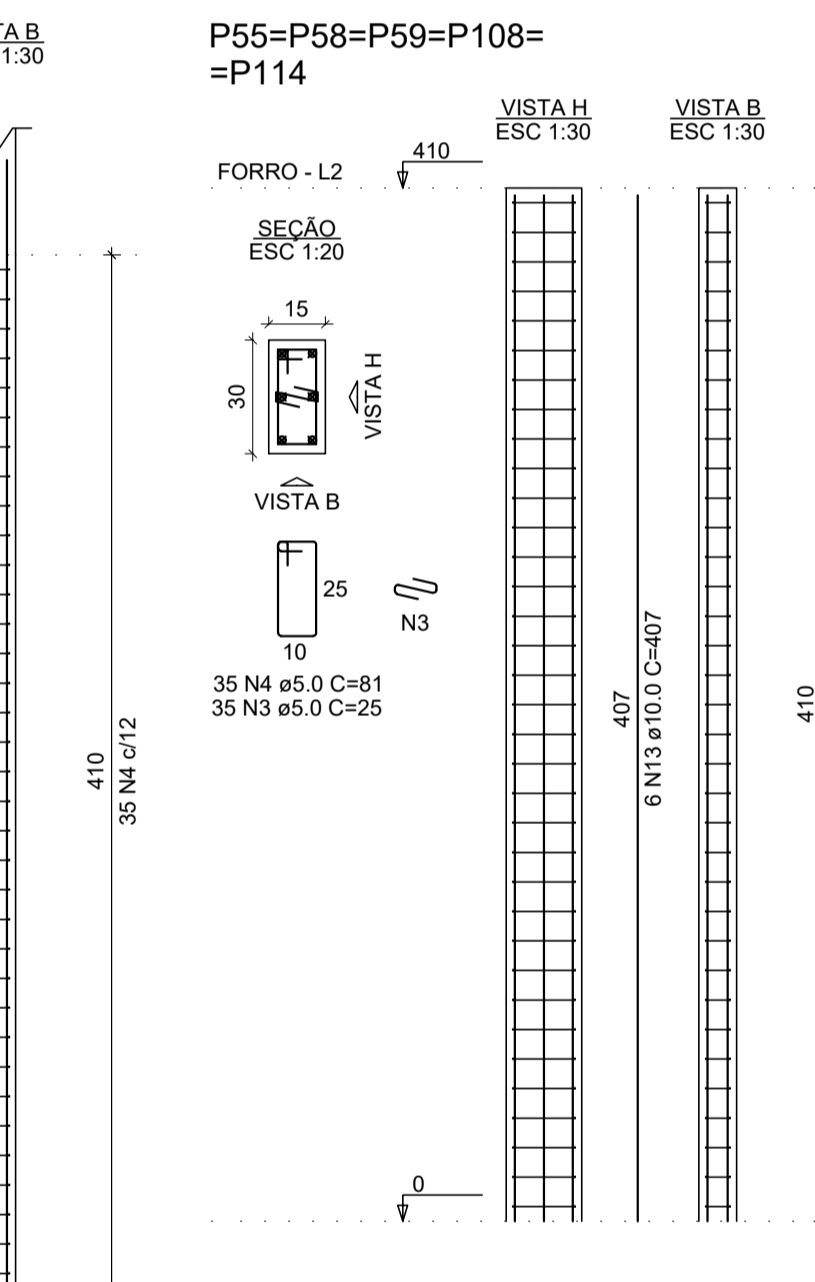
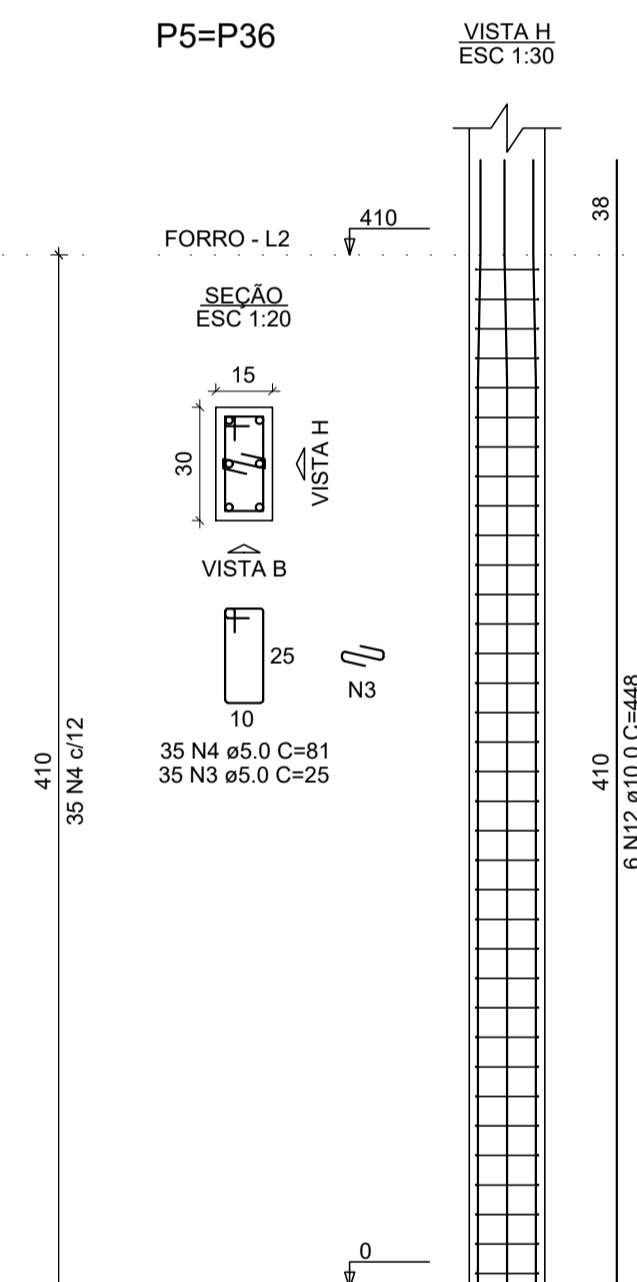
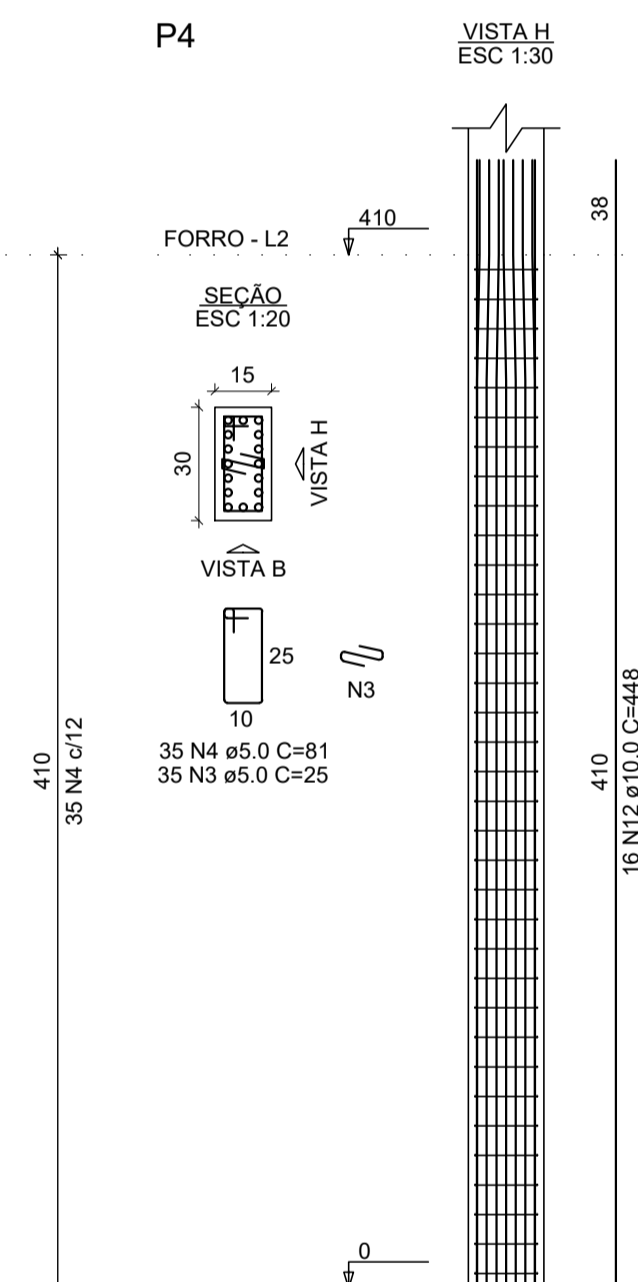
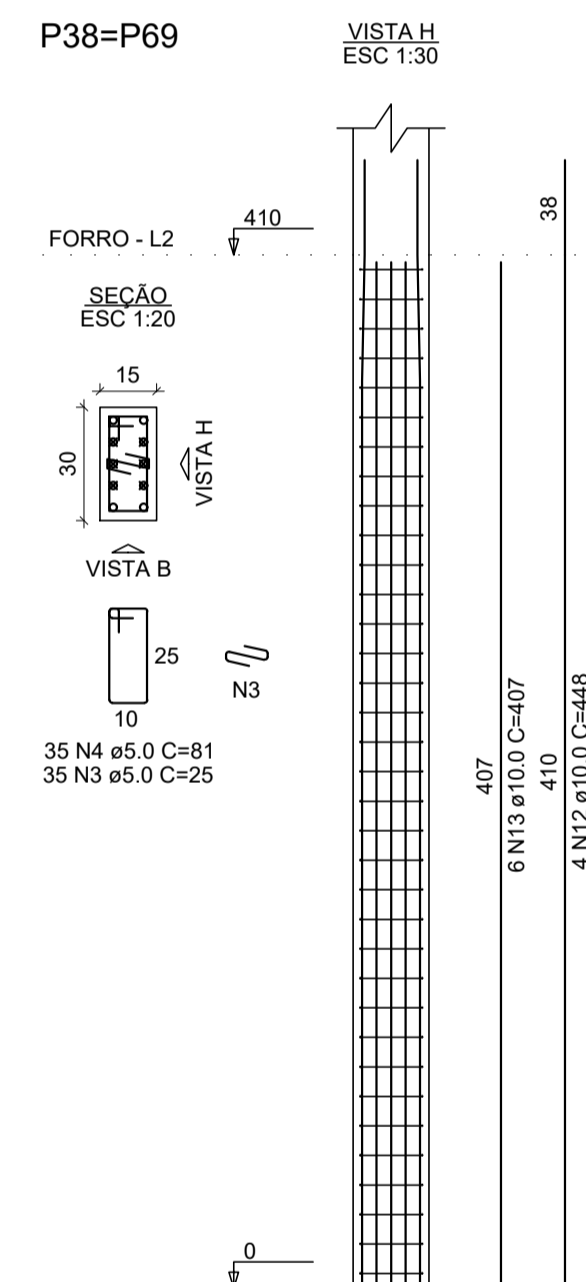
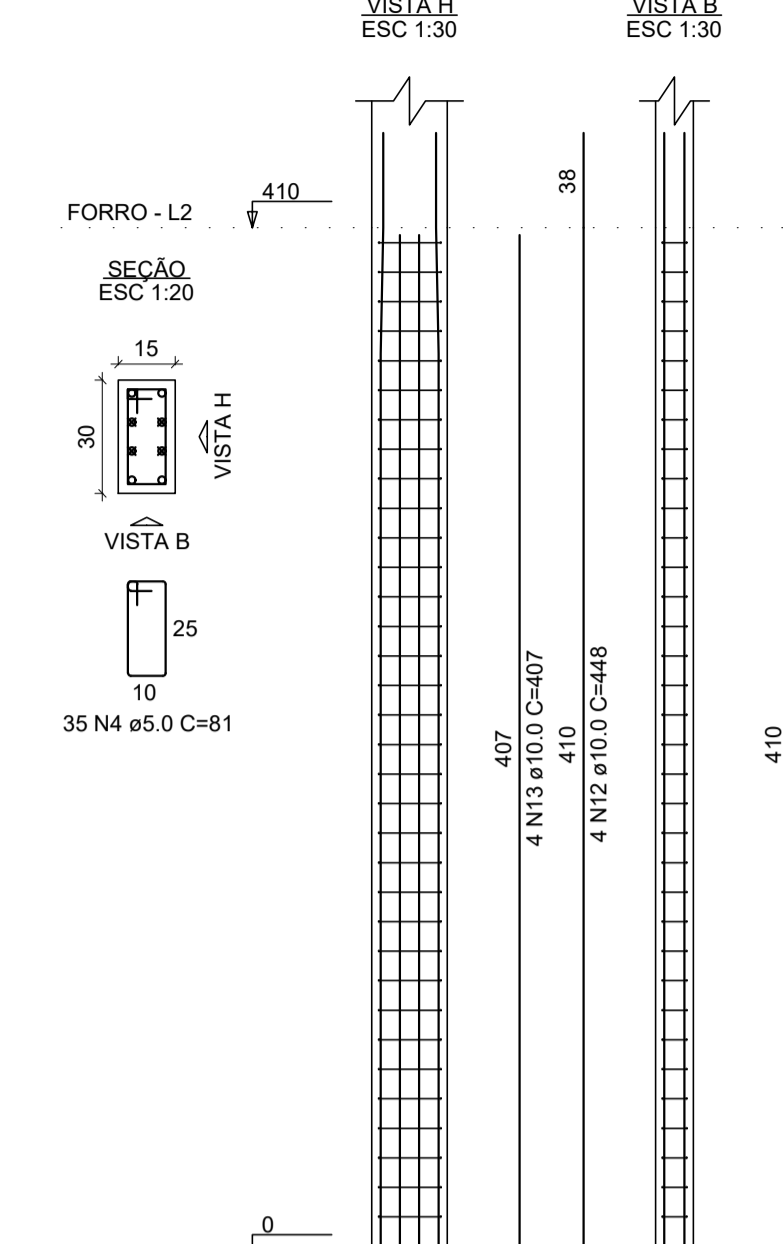
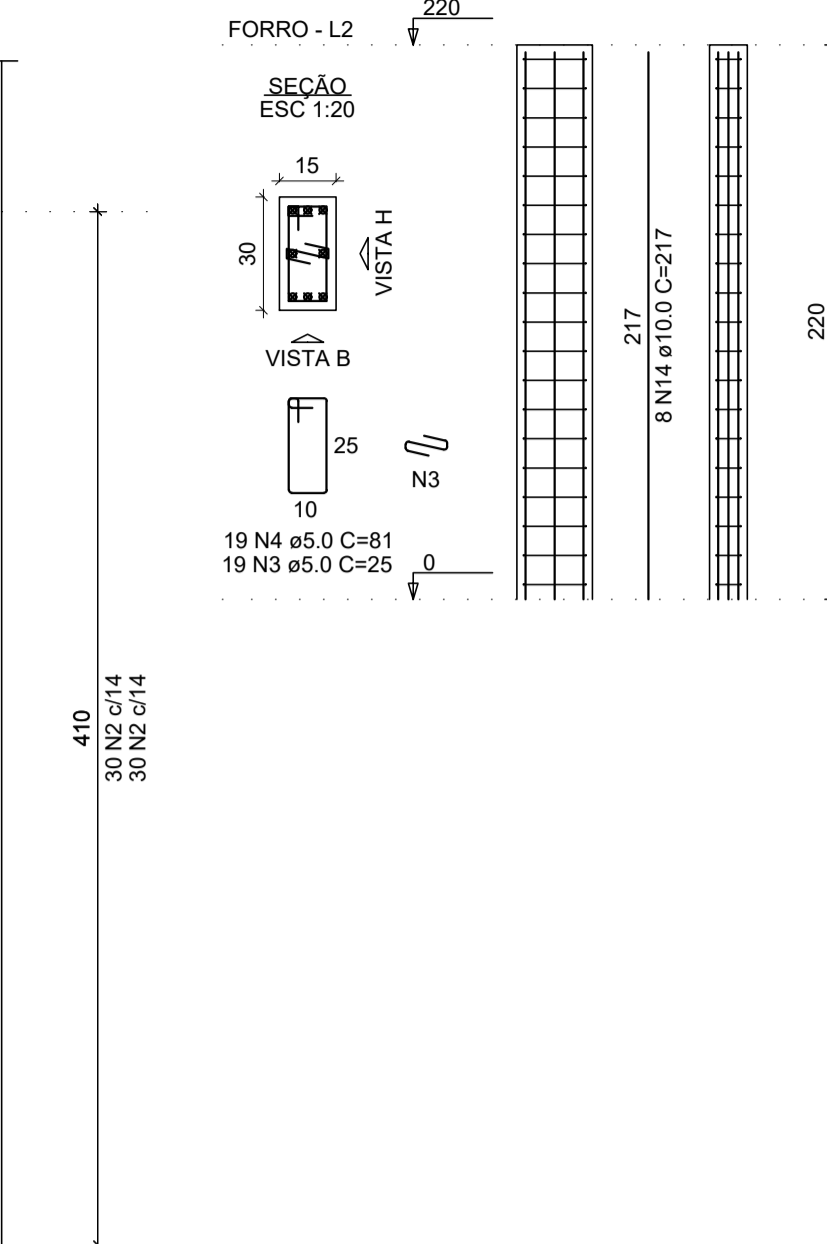
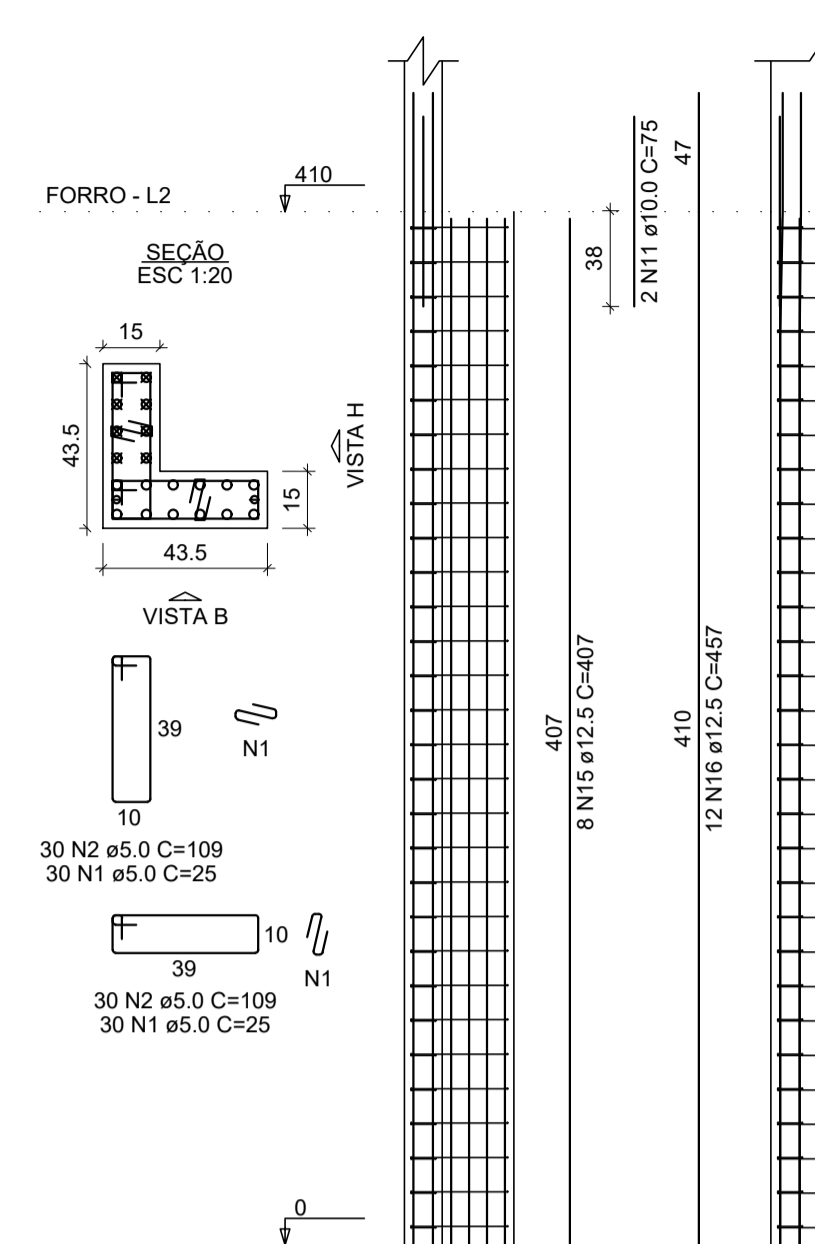
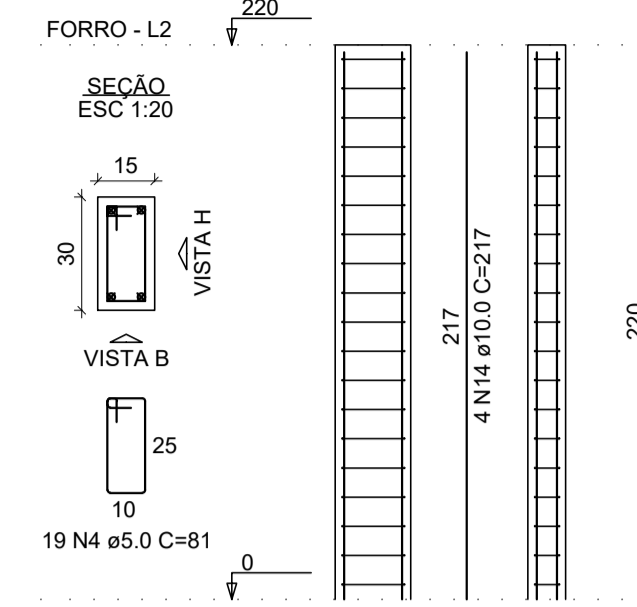
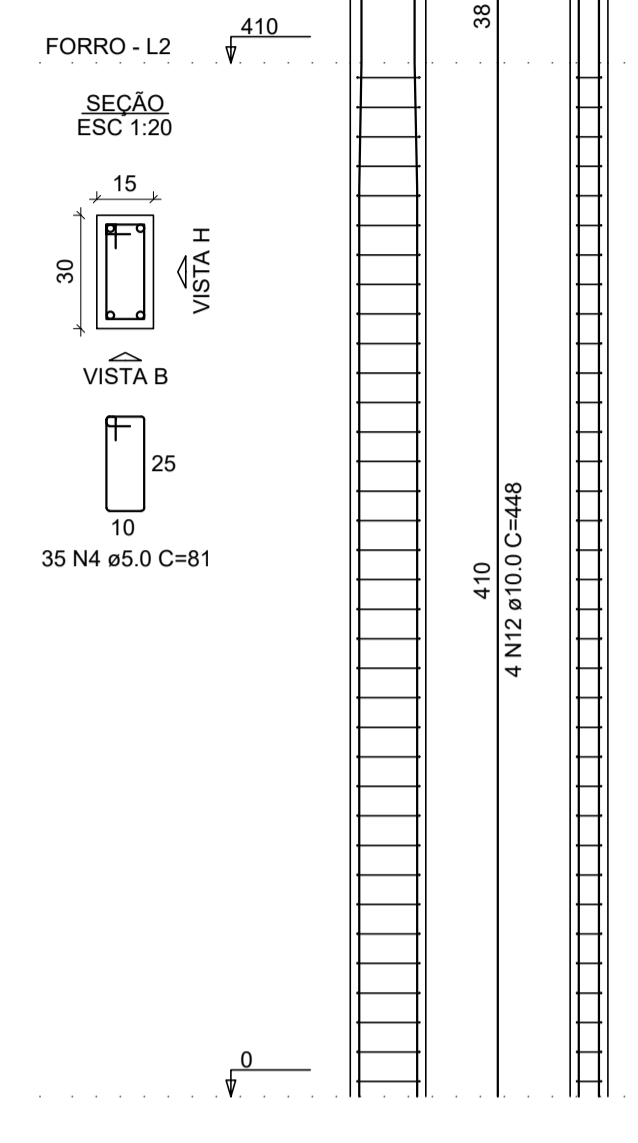
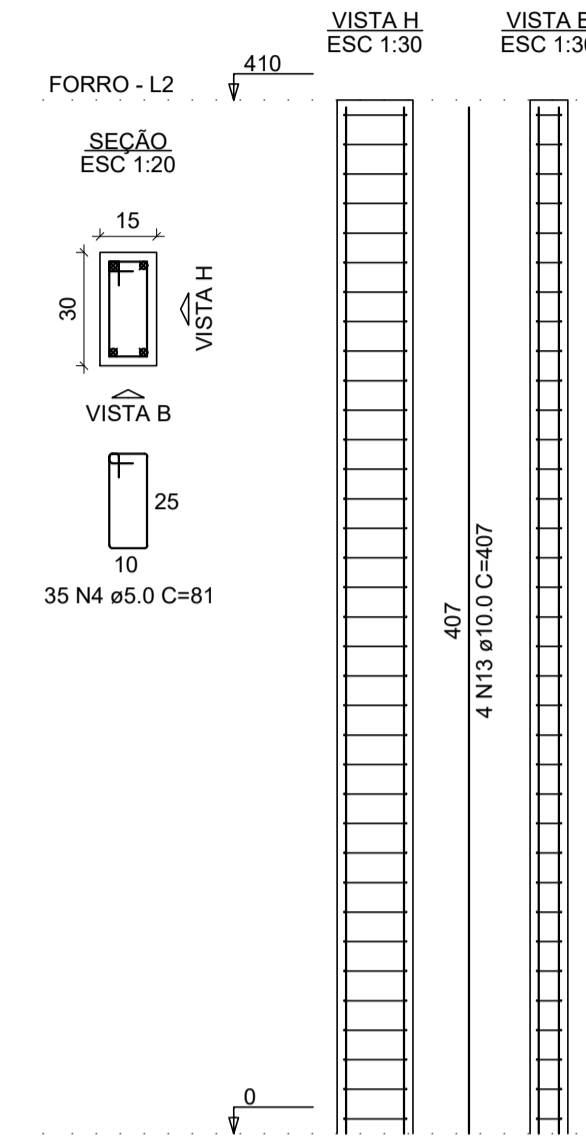

RELAÇÃO DO AÇO

P3	P4	2xP5
P6	41xP14	19xP16
2xP29	P30	3xP37
2xP38	5xP55	P61
P70	P84	2xP85
4xP87		

AÇO	N	DIAM (mm)	QUANT	C.UNIT (cm)	C.TOTAL (cm)
CA60	1	5.0	60	25	1500
	2	5.0	95	109	10355
	3	5.0	474	25	11850
	4	5.0	2612	81	211572
	5	5.0	105	101	10605
	6	5.0	35	101	3535
	7	5.0	70	30	2100
	8	5.0	70	111	7770
	9	5.0	280	40	11200
	10	5.0	140	111	15540
	11	10.0	2	75	150
	12	10.0	154	448	68992
	13	10.0	258	407	105006
	14	10.0	16	217	3472
	15	12.5	8	407	3256
	16	12.5	12	457	5484

RESUMO DO AÇO

AÇO	DIAM (mm)	C.TOTAL (m)	QUANT + 10% (Barras)	UNIT	PESO + 10% (kg)
CA50	10.0	1776.2	163	12 m	1204.6
CA60	12.5	87.4	9	12 m	92.6
		2860.3	-	rolo (170 kg)	485
PESO TOTAL (kg)					
CA50					1297.2
CA60					485

Volume de concreto (C-25) = 17.54 m³  
Área de forma = 332.34 m²

	
PROJETO 	GERÊNCIA DE PROJETOS DENIS DE SOUZA SILVA CREA: MG-127.216/D COORDENAÇÃO DE PROJETOS ALOISIO CAETANO FERREIRA CREA: MG-97.132/D RESPONSÁVEL TÉCNICO ENG. CIVIL FLÁVIA C. BARBOSA CREA: MG-187.842/D PROJETO WILLIAM BARADEL LARI DESENHO WILLIAM BARADEL LARI
EMPREENDIMENTO <b>IMPLANTAÇÃO DO CEMAPA E CENTRO POP</b>	
ENDEREÇO RUA PROJETADA, BAIRRO SANTA CECÍLIA POUSO ALEGRE - MINAS GERAIS	DISCIPLINA ESTRUTURAL FASE DO PROJETO EXECUTIVO ASSUNTO PROJETO ESTRUTURAL DE CONCRETO ARMADO FORMAS E FERRAGENS PILARES
DATA INICIAL 13/04/2020	ESCALA INDICADA
REVISÃO ROO	ARQUIVO DAC-PMPA-CEPOP-PE-EST-ROO.DWG
FOLHA Nº <b>10/28</b>	

REV. 00	13/04/20	EMISSÃO INICIAL	DAC
REVISÃO: DATA :	DESCRIÇÃO:		RESP.: