

P1=P7=P8=P10=P11=P28=
=P33=P40=P43=P52=P63=
=P64=P74=P113=P130

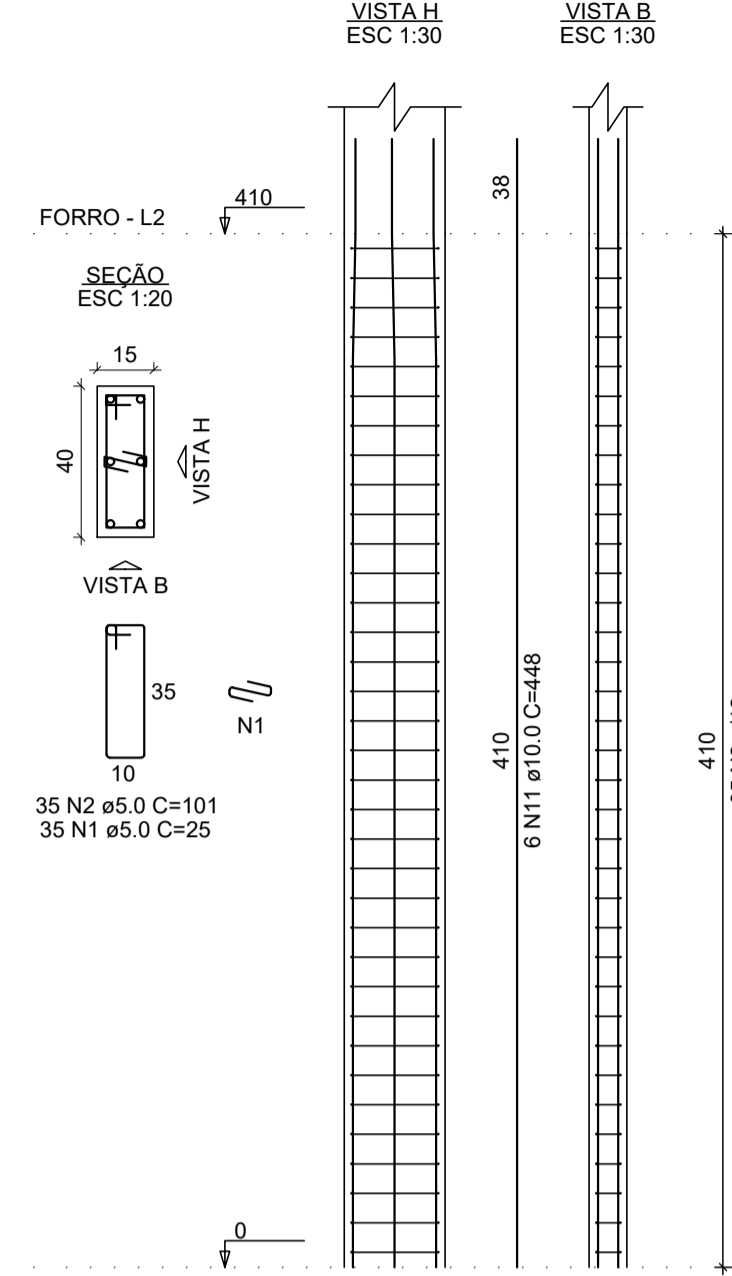

P104=P123

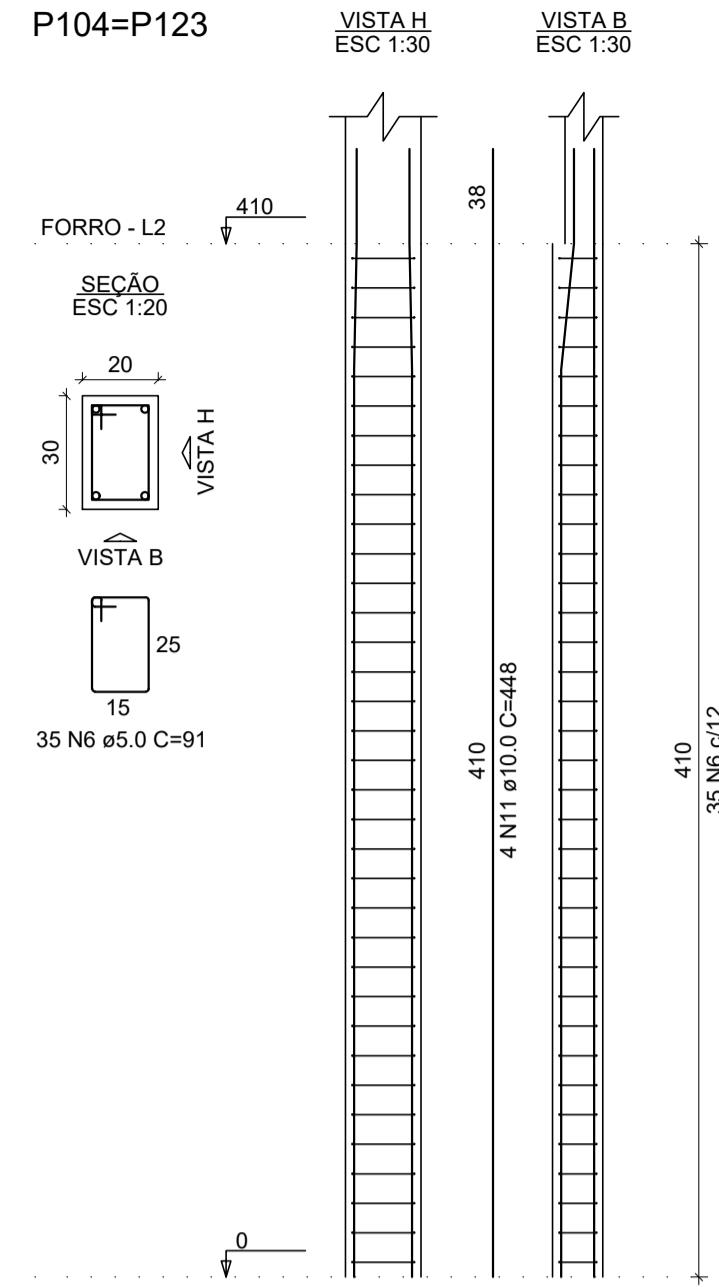

P110

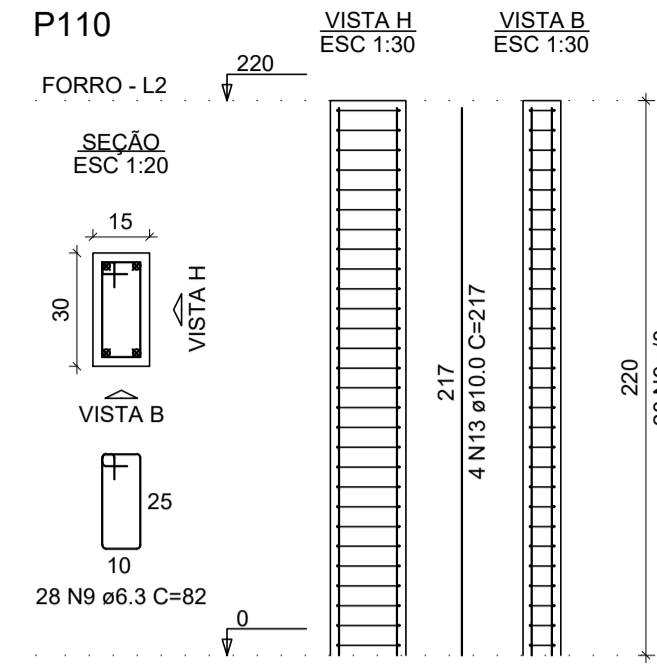

P111

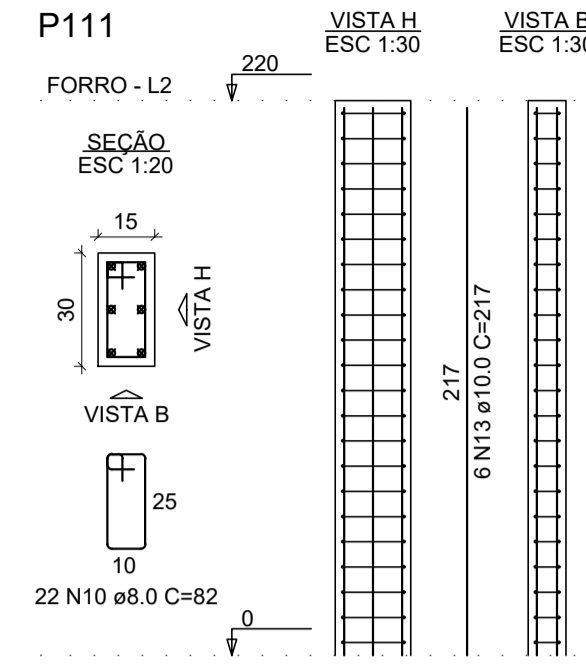

P112

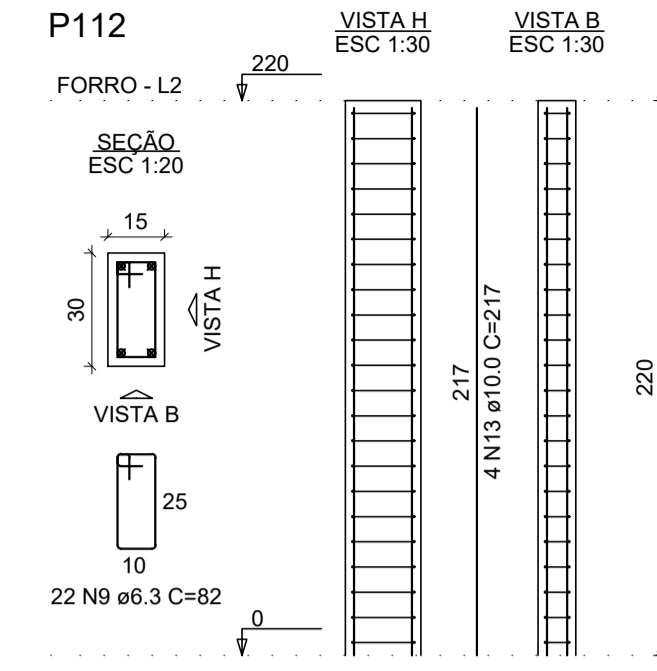

P119

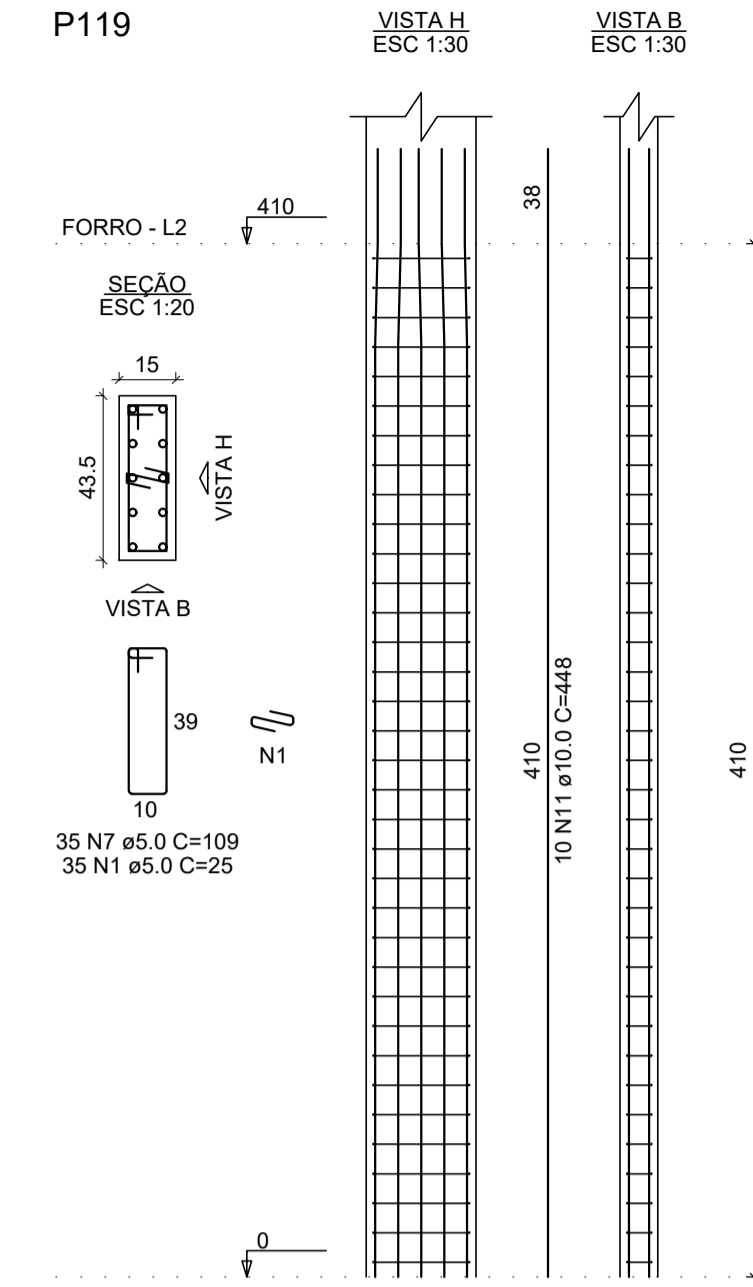

P12=P22=P39=P53=P117=
=P129=P134

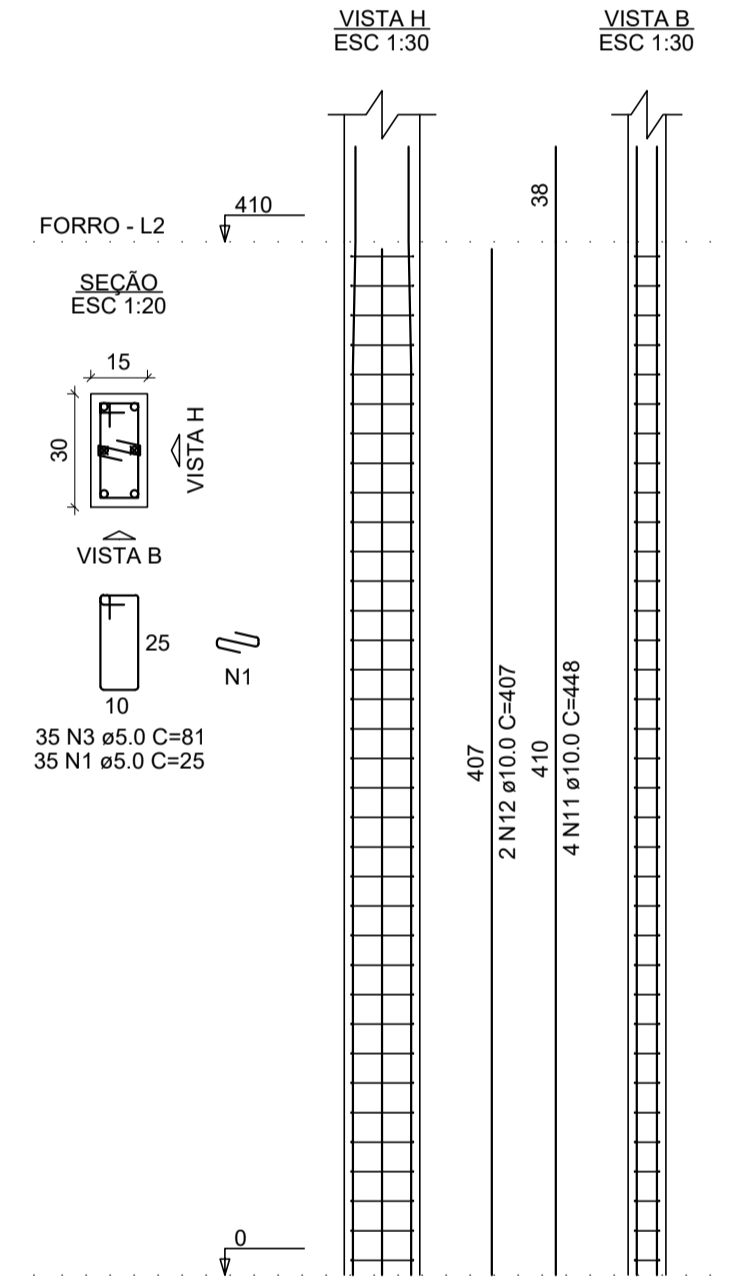

P120

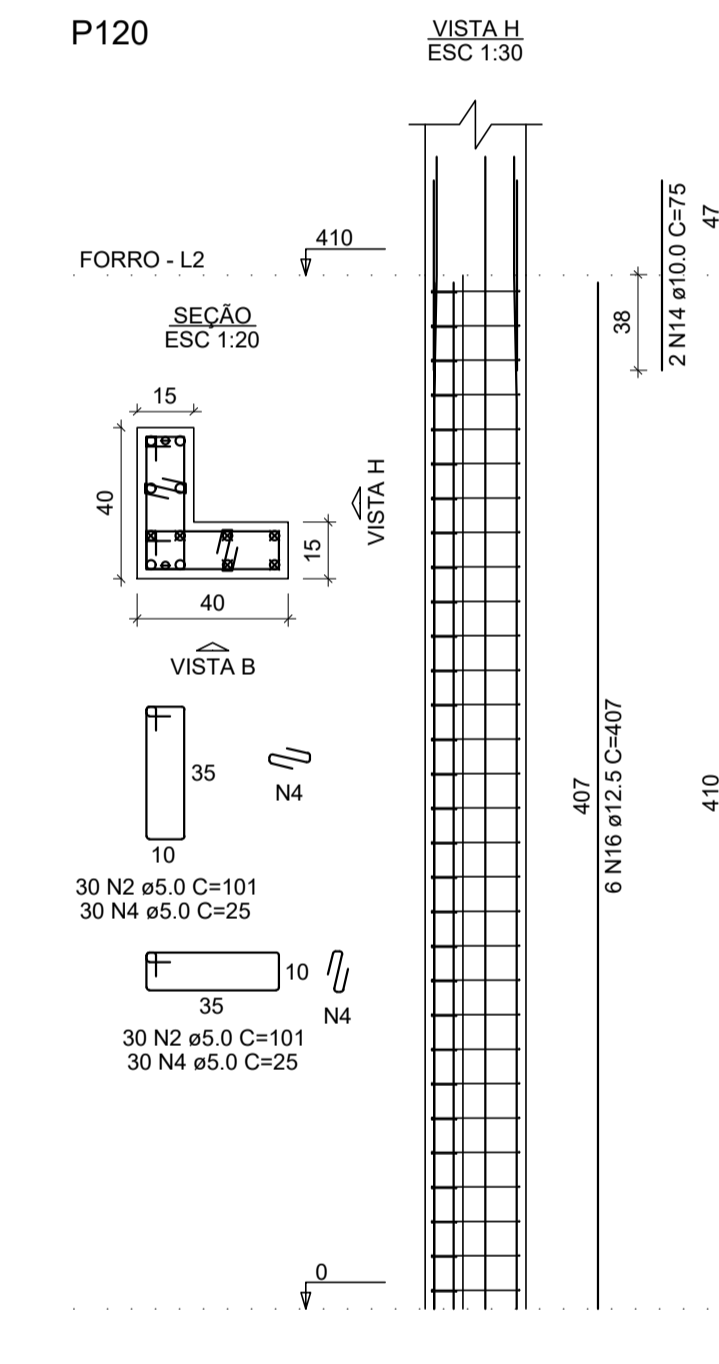

P122

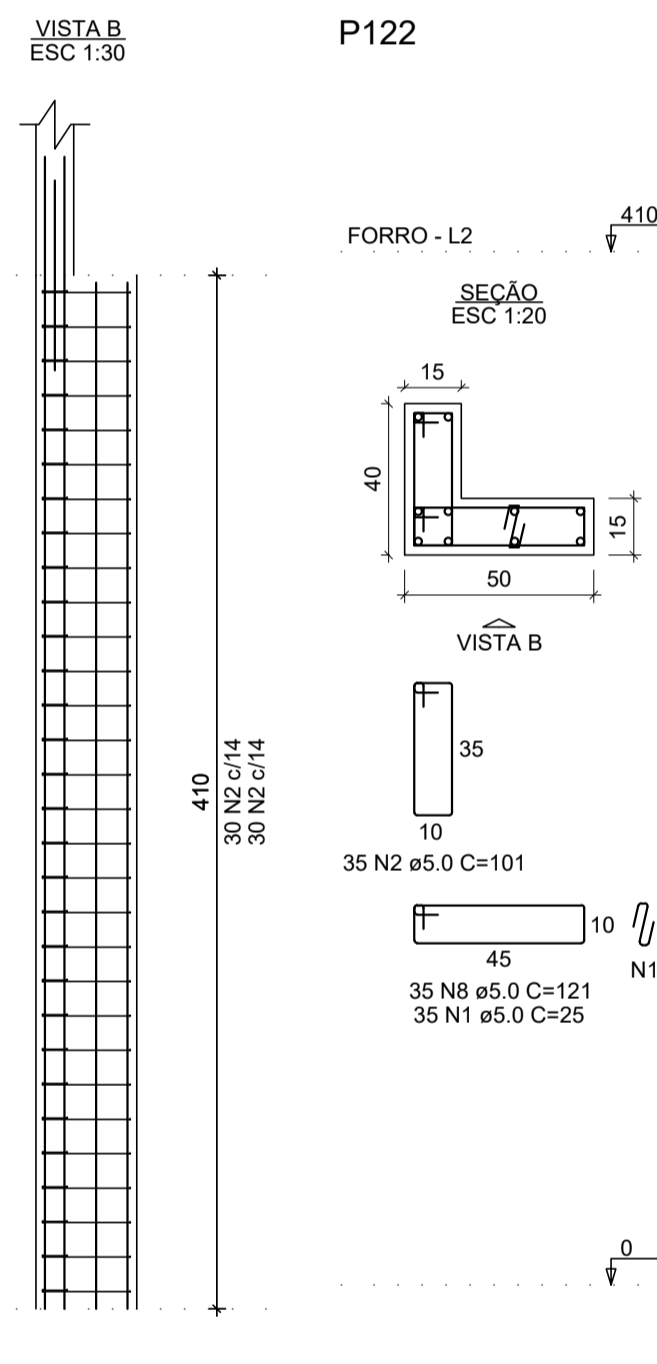

P128

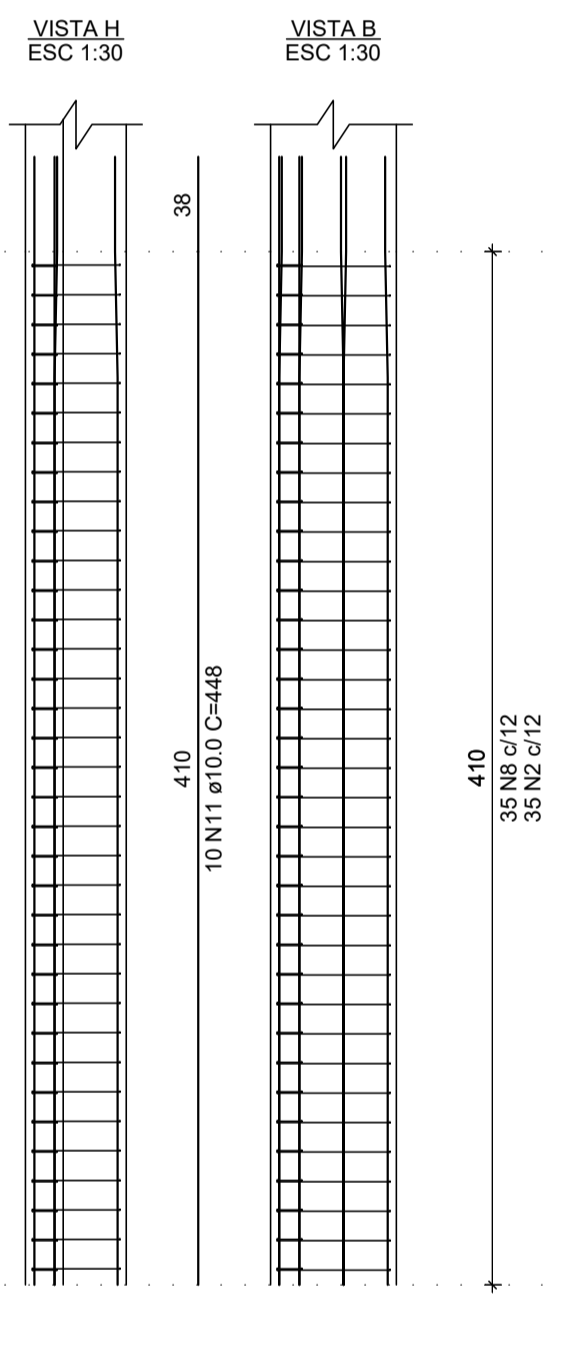

P128

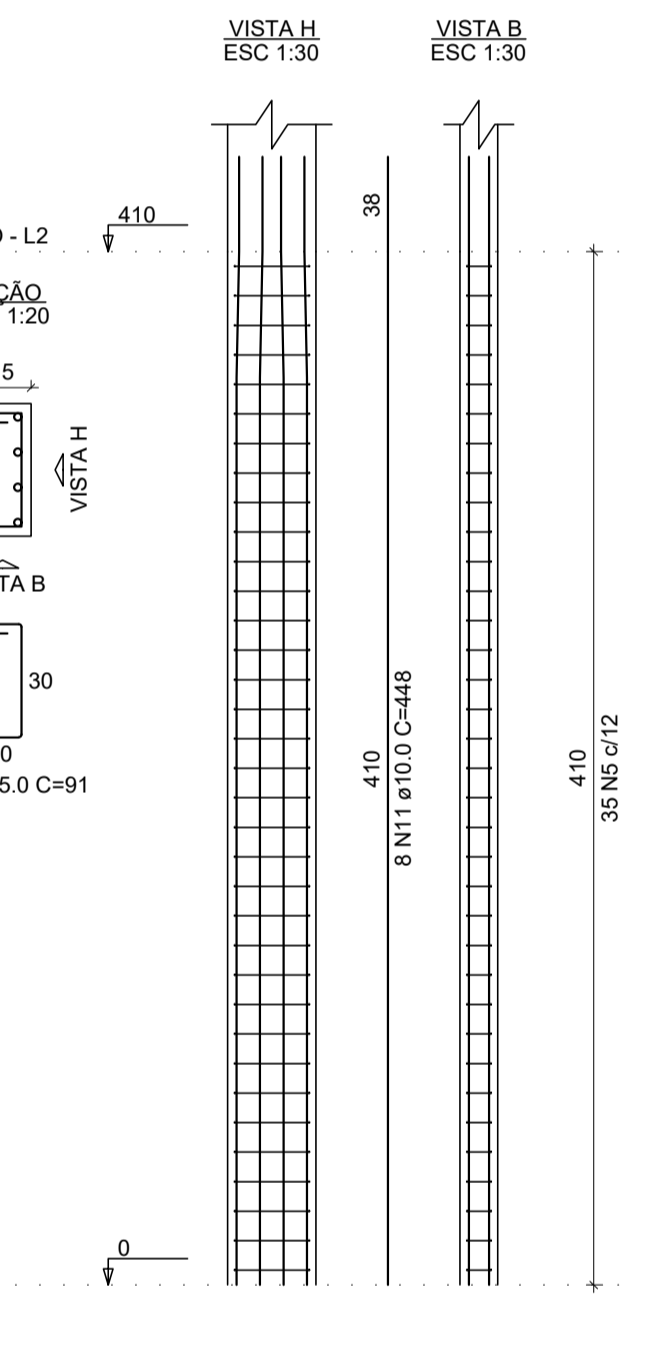

P13=P23=P54

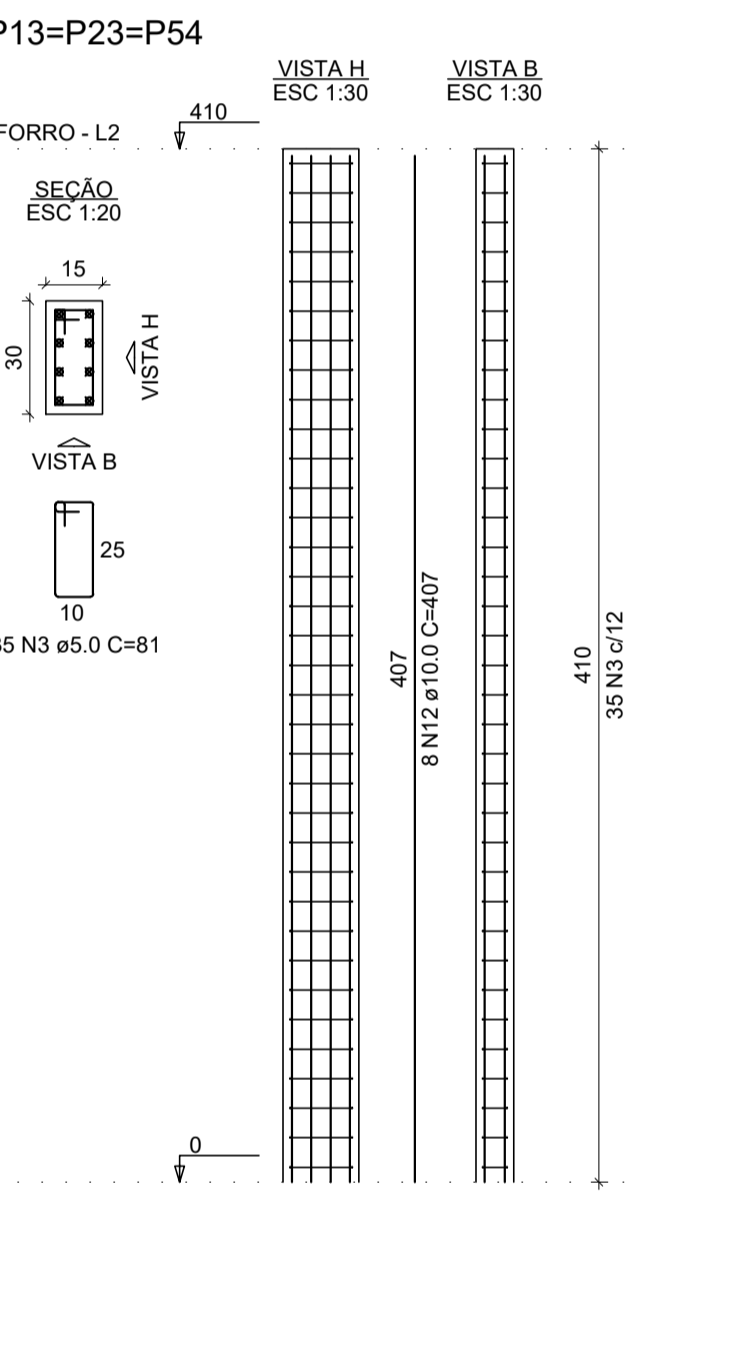

RELAÇÃO DO AÇO

AÇO	N	DIAM (mm)	QUANT	C.UNIT (cm)	C.TOTAL (cm)
CA60	1	5.0	875	25	21875
	2	5.0	620	101	62620
	3	5.0	520	81	42120
	4	5.0	90	25	2250
	5	5.0	100	91	9100
	6	5.0	70	91	6370
CA50	7	5.0	35	109	3815
	8	5.0	70	121	8470
	9	6.3	50	82	4100
	10	8.0	22	82	1804
	11	10.0	166	448	74368
	12	10.0	60	407	24420
	13	10.0	14	217	3038
	14	10.0	2	75	150
	15	12.5	36	457	16452
	16	12.5	6	407	2442

RESUMO DO AÇO

AÇO	DIAM (mm)	C.TOTAL (m)	QUANT + 10% (Barras)	UNIT	PESO + 10% (kg)
CA50	6.3	41	4	12 m	11
	8.0	18	2	12 m	7.8
	10.0	1019.8	94	12 m	691.6
	12.5	188.9	18	12 m	200.2
	5.0	1566.2	-	rolo (170 kg)	265.5

PESO TOTAL (kg)
CA50 910.7
CA60 265.5

Volume de concreto (C-25) = 9.33 m³
Área de forma = 173.51 m²

P133

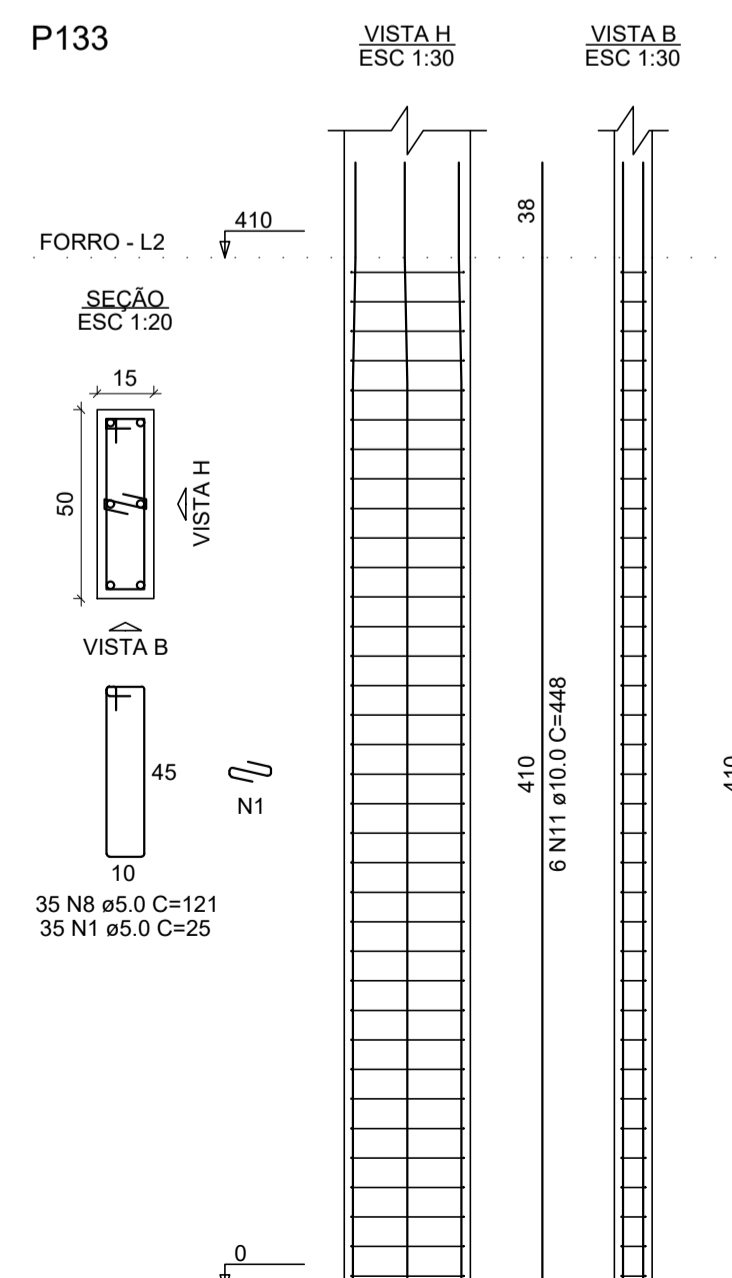

P17

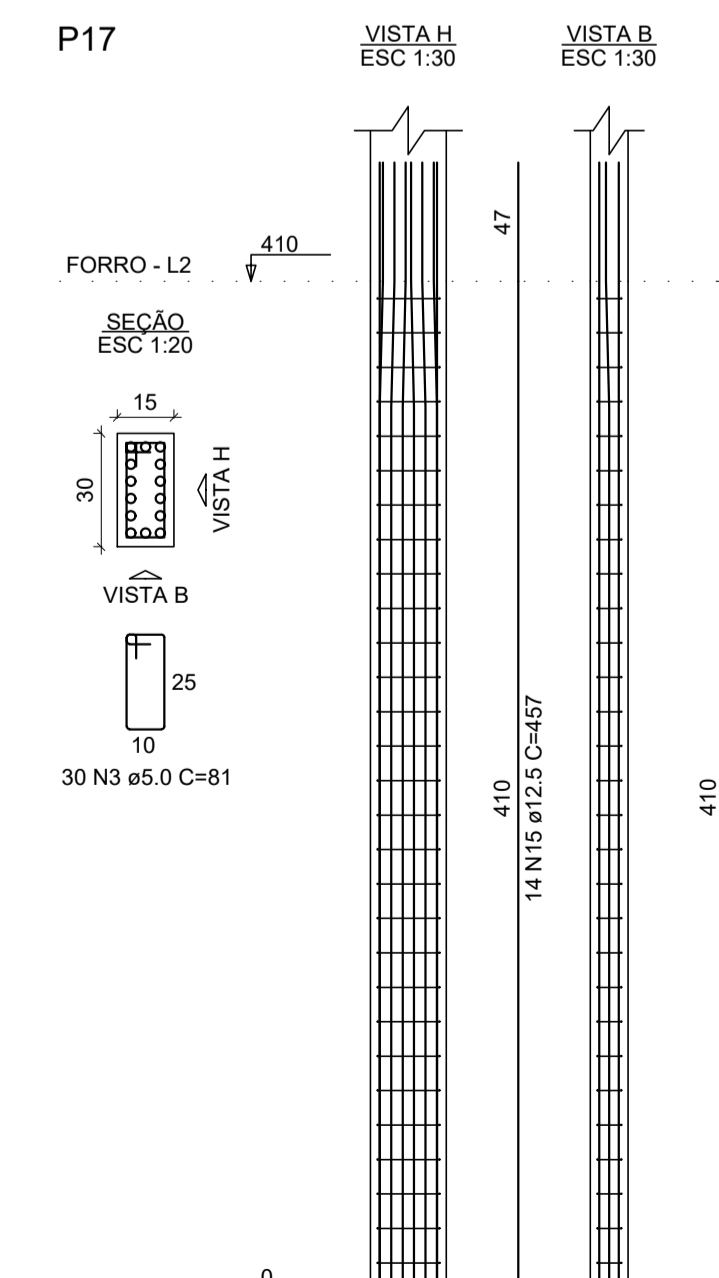

P18

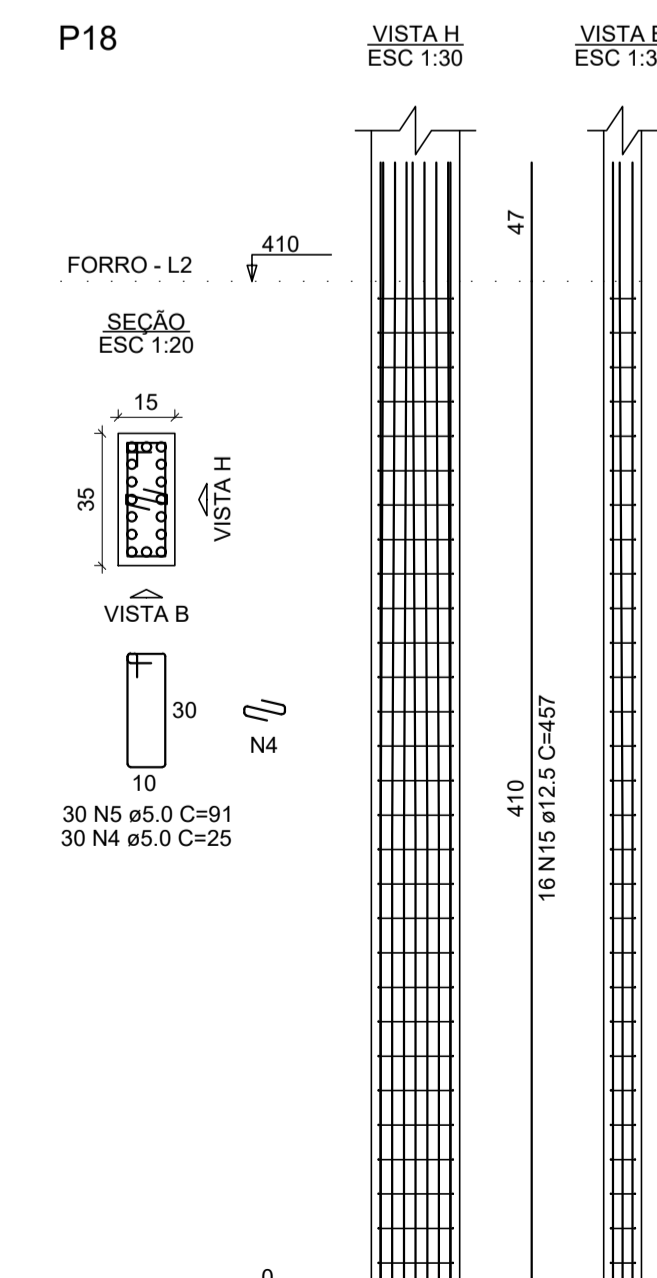

P19

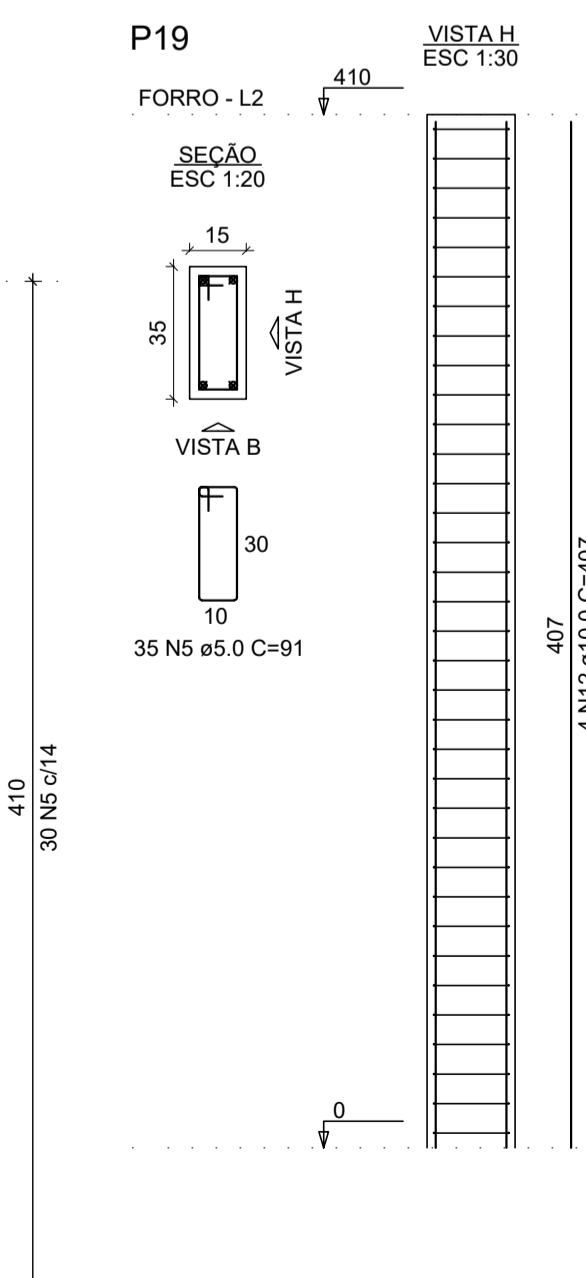

P2

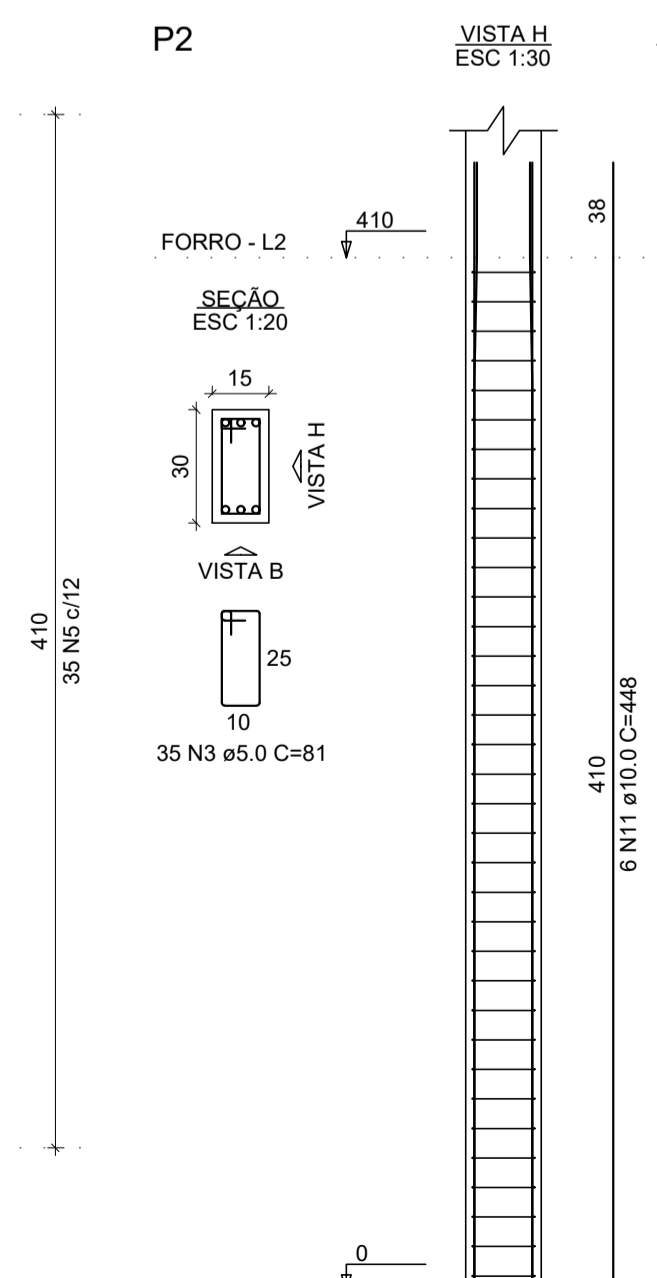

P21=P48=P75

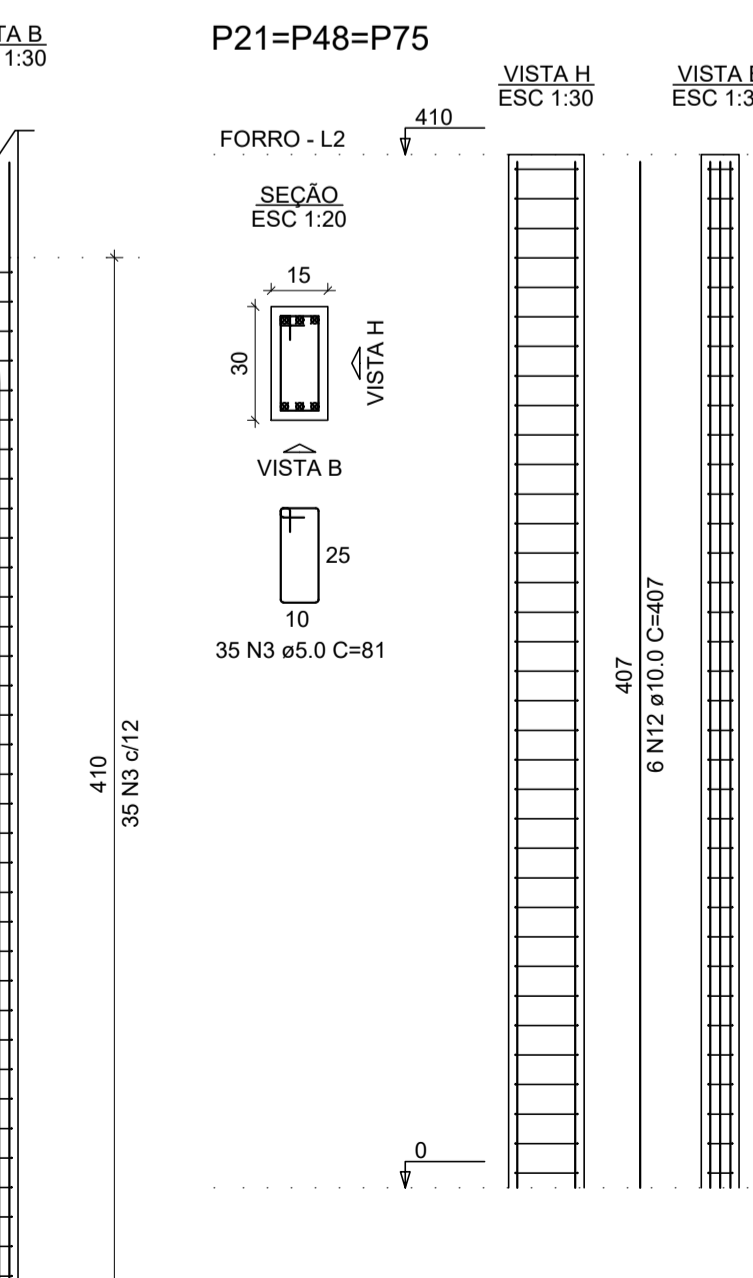

REV. 00 | 13/04/20 | EMISSÃO INICIAL | DAC

REVISÃO: DATA : | DESCRIÇÃO: | RESP.:



Prefeitura Municipal
de Pouso Alegre

<p>PROJETO</p>  <p>Rua Miguel Vianna, nº 81, Sala 12 Bairro Morro Chic CEP: 37500-080 - Itajubá / MG Tel: (35) 3623-5720 www.dacengenharia.com.br</p>	<p>GERÊNCIA DE PROJETOS DENIS DE SOUZA SILVA CREA: MG-127.216/D</p> <p>COORDENAÇÃO DE PROJETOS ALOISIO CAETANO FERREIRA CREA: MG-97.132/D</p> <p>RESPONSÁVEL TÉCNICO ENGR. CIVIL FLÁVIA C. BARBOSA CREA: MG-187.842/D</p> <p>PROJETO WILLIAM BARADEL LARI</p> <p>DESENHO WILLIAM BARADEL LARI</p>
--	---

EMPREENDIMENTO

IMPLANTAÇÃO DO CEMAPA E CENTRO POP

<p>ENDEREÇO RUA PROJETADA, BAIRRO SANTA CECÍLIA POUSO ALEGRE - MINAS GERAIS</p> <p>ASSUNTO PROJETO ESTRUTURAL DE CONCRETO ARMADO FORMAS E FERRAGENS PILARES</p>	<p>DISCIPLINA ESTRUTURAL</p> <p>FASE DO PROJETO EXECUTIVO</p> <p>FOLHA Nº. 09/28</p>
---	---

DATA INICIAL | ESCALA | REVISÃO | ARQUIVO
13/04/2020 | INDICADA | ROO | DAC-PMPA-CEPOP-PE-EST-ROO.DWG