

PROJETO ESTRUTURAL - CONSTRUÇÃO DA UBS ÁRVORE GRANDE

Escala indicada

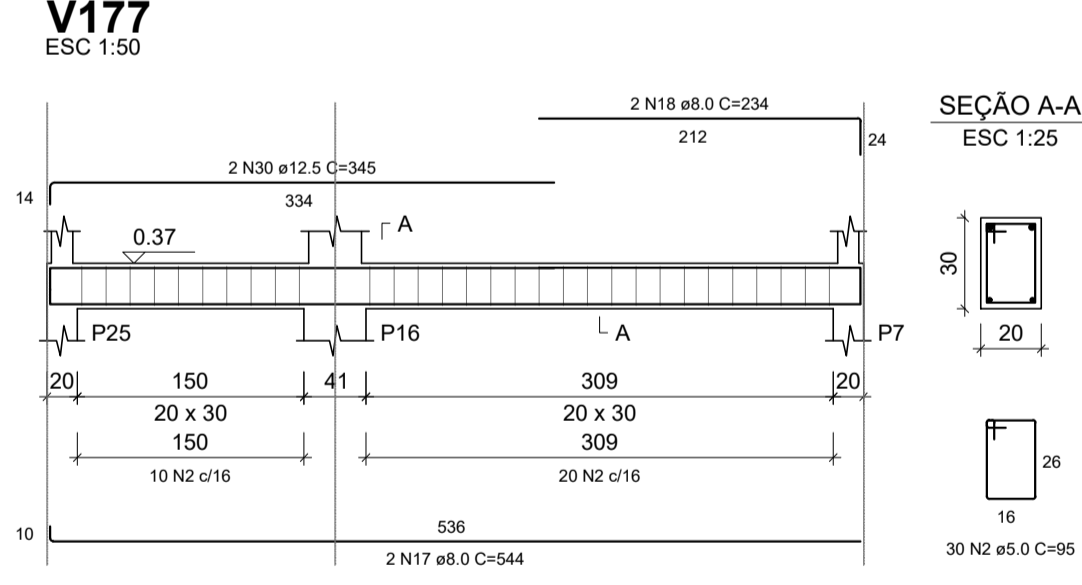
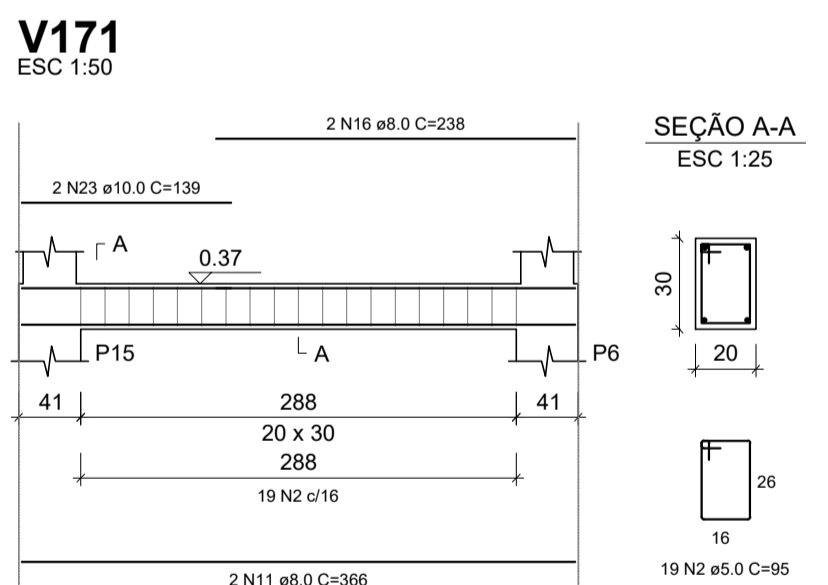
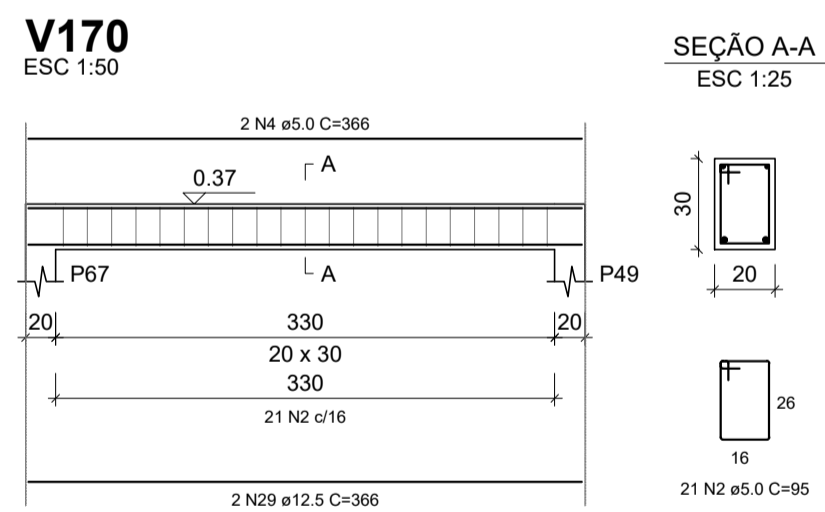
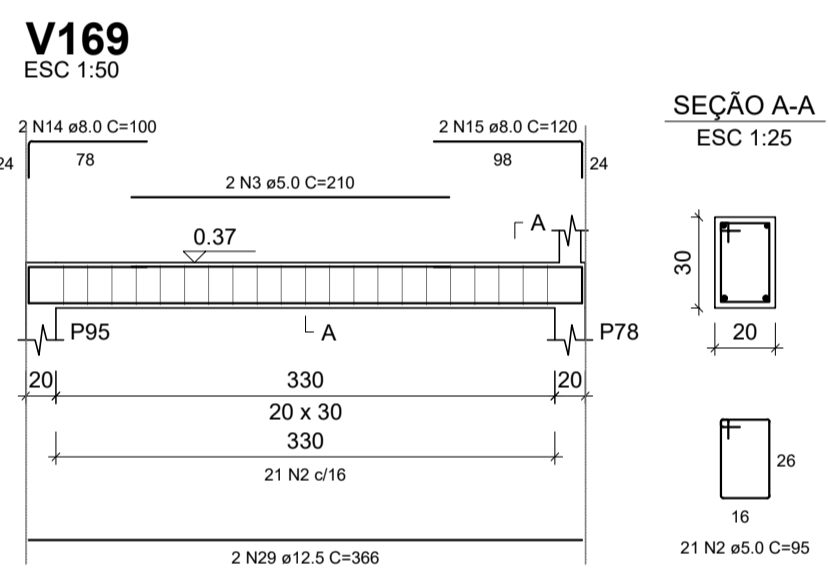
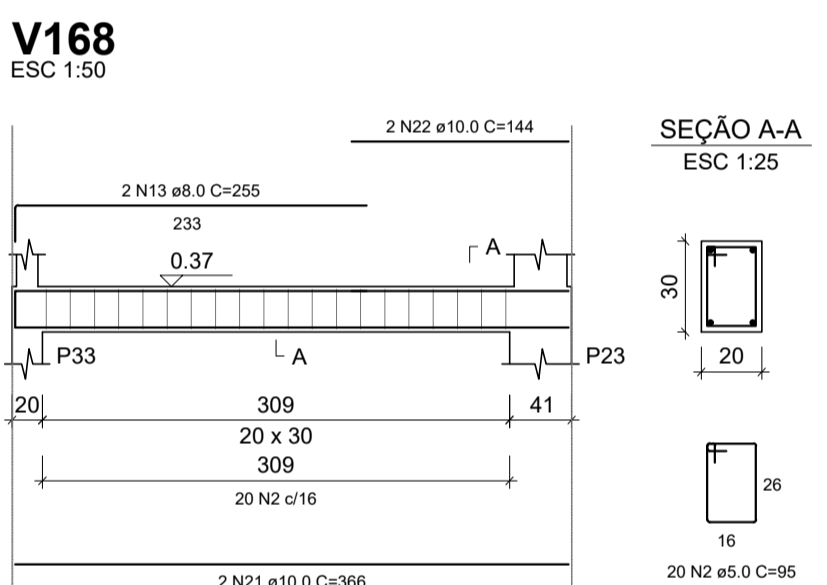
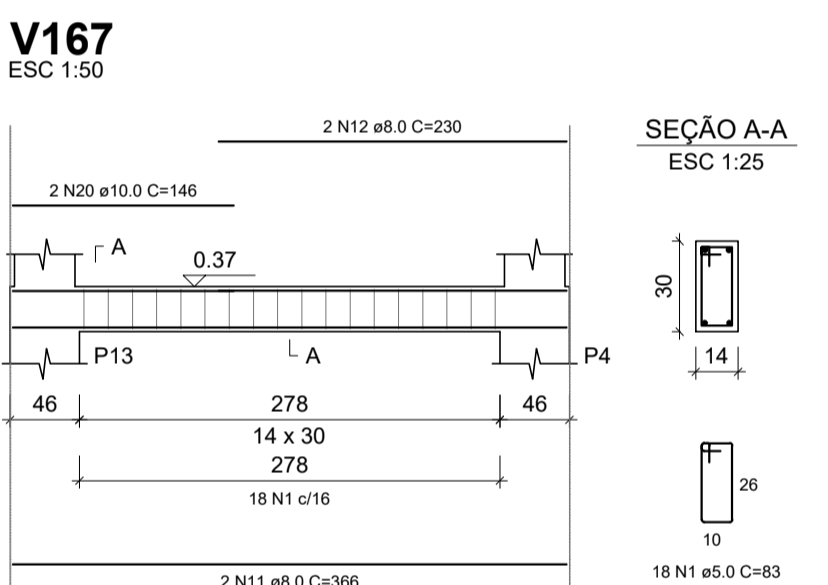
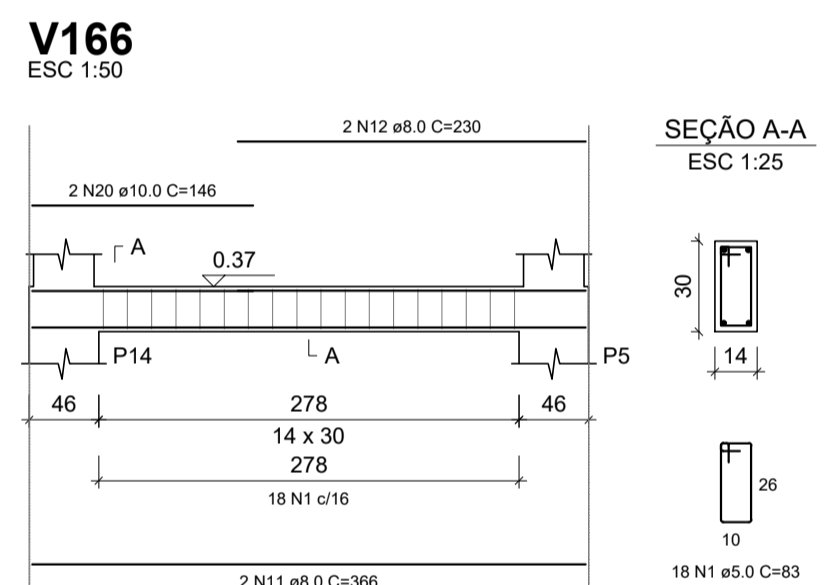
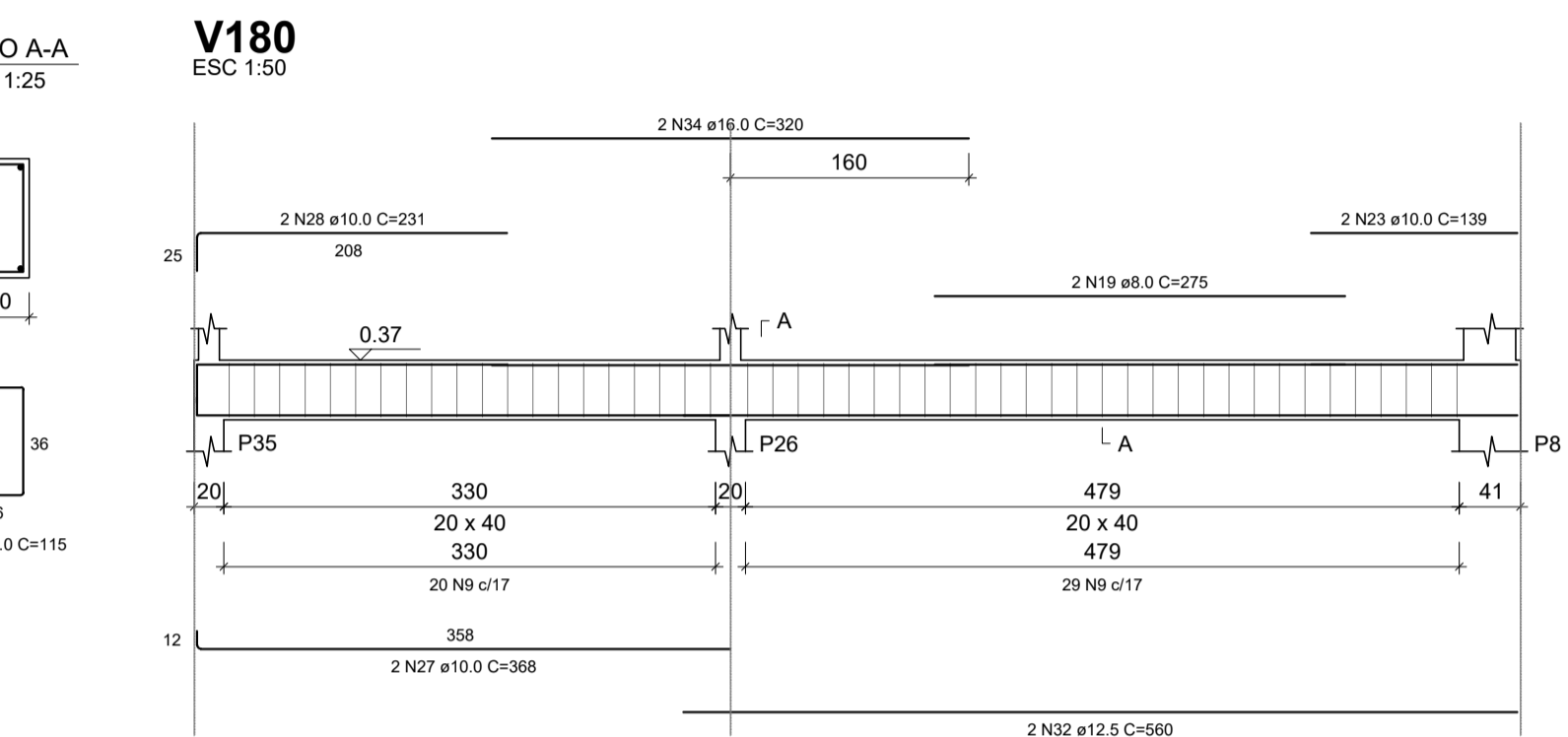
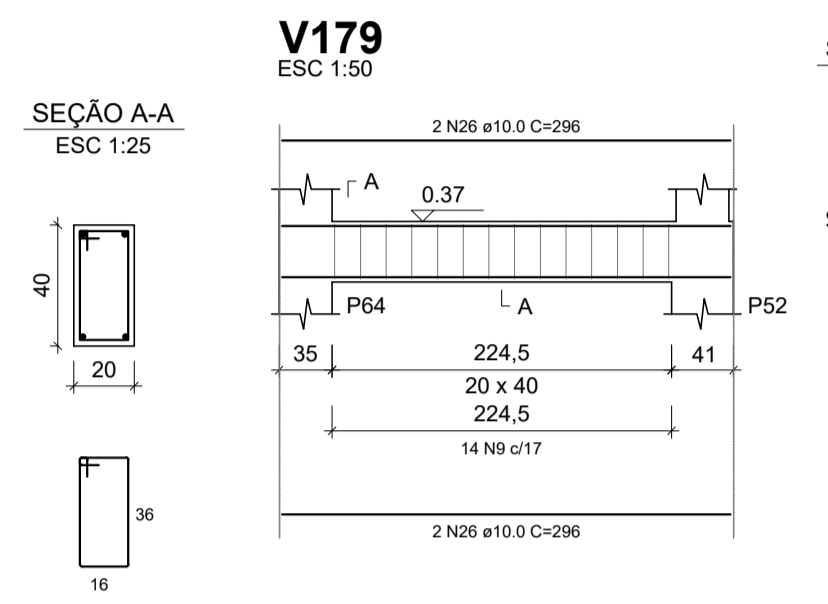
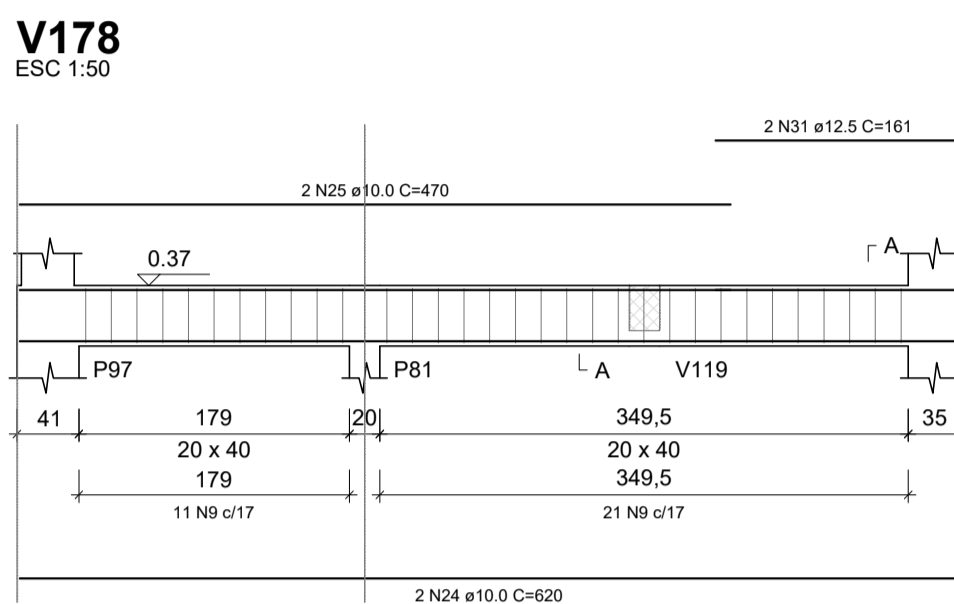
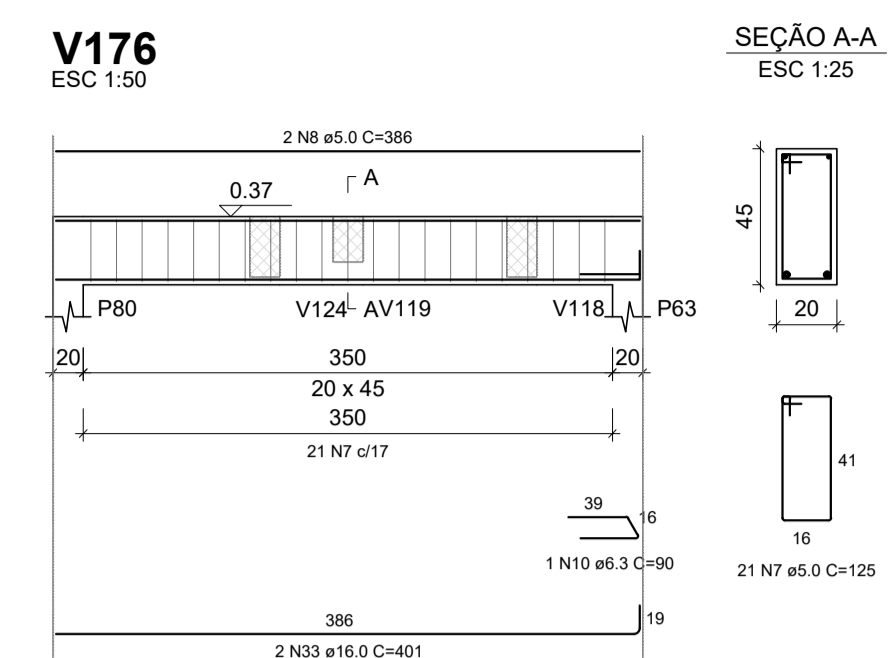
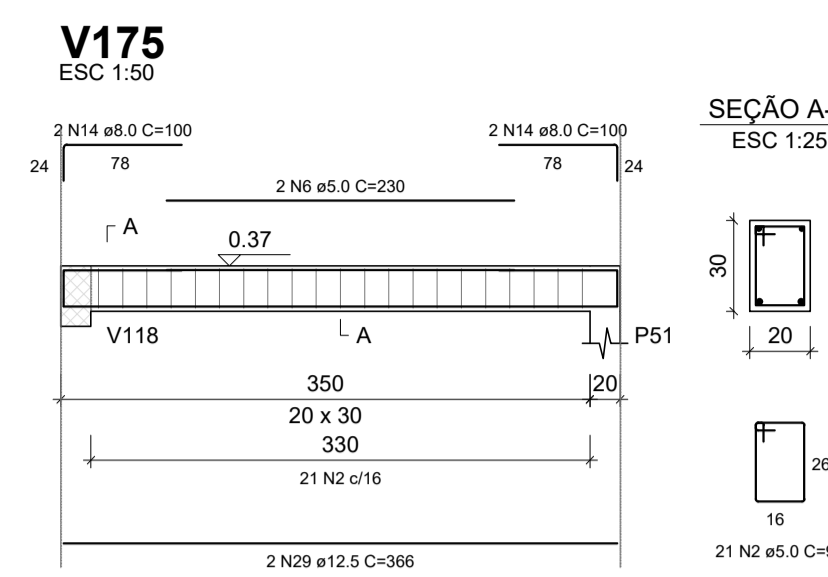
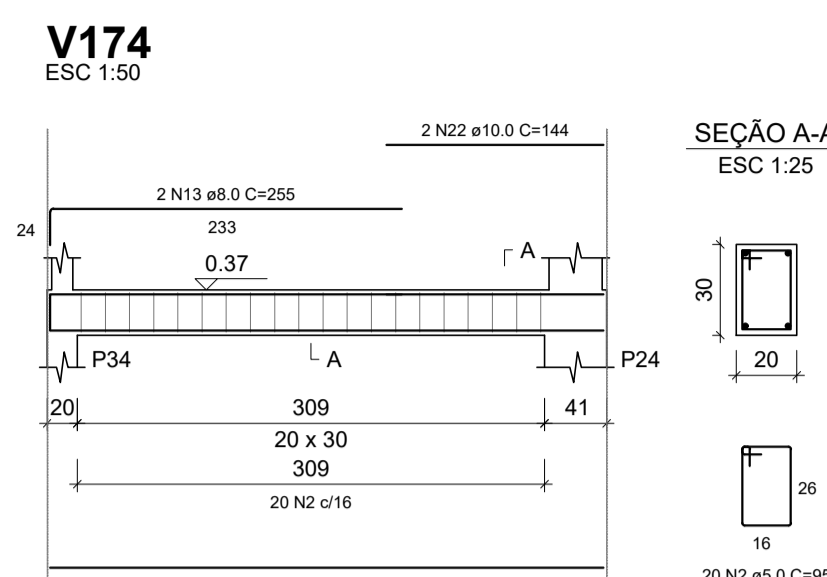
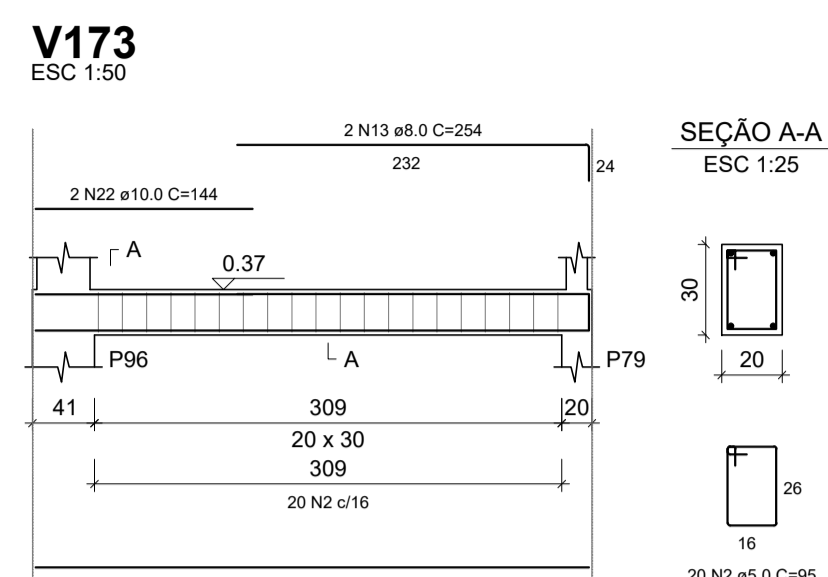
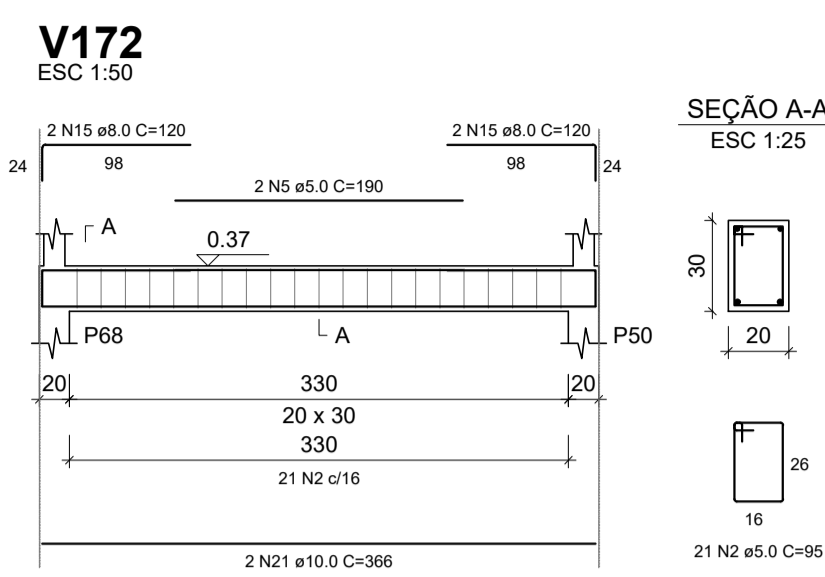

RELAÇÃO DO AÇO

AÇO	N	DIAM (mm)	QUANT	C.UNIT (cm)	C.TOTAL (cm)
CA60	1	5.0	36	83	2988
	2	5.0	193	95	18335
	3	5.0	2	210	420
	4	5.0	2	366	732
	5	5.0	2	190	380
	6	5.0	2	230	460
	7	5.0	21	125	2625
	8	5.0	2	386	772
	9	5.0	95	115	10925
	10	6.3	1	90	90
	11	6.3	6	366	2196
	12	8.0	4	230	920
	13	8.0	6	255	1530
	14	8.0	6	100	600
	15	8.0	6	120	720
	16	8.0	2	238	476
	17	8.0	2	544	1088
	18	8.0	2	234	468
	19	8.0	2	275	550
	20	10.0	4	146	584
	21	10.0	8	366	2928
	22	10.0	6	144	864
	23	10.0	4	139	556
	24	10.0	2	620	1240
	25	10.0	2	470	940
	26	10.0	4	296	1184
	27	10.0	2	368	736
	28	10.0	2	231	462
	29	12.5	6	366	2196
	30	12.5	2	345	690
	31	12.5	2	161	322
	32	12.5	2	560	1120
	33	16.0	2	401	802
	34	16.0	2	320	640

RESUMO DO AÇO

AÇO	DIAM (mm)	C.TOTAL (m)	PESO + 10% (kg)
CA50	6.3	0.9	0.2
	8.0	85.5	37.1
	10.0	94.9	64.4
	12.5	43.3	45.9
	16.0	14.4	25
CA60	5.0	376.4	63.8
PESO TOTAL (kg)			
CA50		172.6	
CA60		63.8	

Volume de concreto (C-30) = 4.21 m³
Área de forma = 55.92 m²



	
 <p>Rua Miguel Vianna, nº 81, Sala 12 Bairro Morro Chic CEP: 37500-080 - Itajubá / MG Tel: (35) 3623-5720 www.dacengenharia.com.br</p>	<p>GERÊNCIA DE PROJETOS PEDRO HENRIQUE JUSTINIANO ENO CIVIL</p> <p>COORDENAÇÃO DE PROJETOS ALDOISO CAETANO FERREIRA CREA-MG-97.132/D</p> <p>RESPONSÁVEL TÉCNICO ENO FLÁVIA CRISTINA BARBOSA CREA-MG-187.842/D</p> <p>PROJETO WILLIAM BARADEL LARI</p> <p>DESENHO WILLIAM BARADEL LARI</p>
<p>EMPREENDIMENTO CONSTRUÇÃO DA UBS ÁRVORE GRANDE</p>	
<p>ENDEREÇO RUA EDUARDO SOUZA GOUVEIA, B. JARDIM OLÍMPICO POUSO ALEGRE - MINAS GERAIS</p>	<p>DISCIPLINA ESTRUTURAL</p>
<p>ASSUNTO PROJETO ESTRUTURAL EM CONCRETO ARMADO DETALHAMENTO DAS VIGAS BALDRAME</p>	<p>FASE DO PROJETO EXECUTIVO</p>
<p>FOLHA Nº: 15/25</p>	
<p>DATA INICIAL 02/08/2521</p>	<p>ESCALA INDICADA</p>
<p>REVISÃO R00</p>	<p>ARQUIVO DAC-PMPA-ARG-EST-PE-R00.DWG</p>